

PAPER • OPEN ACCESS

Redesign of a Volkswagen Crafter vehicle to a hybrid vehicle having e-motor and diesel engine

To cite this article: Sándor Bodzás *et al* 2022 *IOP Conf. Ser.: Mater. Sci. Eng.* **1237** 012008

View the [article online](#) for updates and enhancements.

You may also like

- [Forming behaviour of stainless steel sheets at different material thicknesses](#)
A Lehmborg, C Sunderkoetter, T Glaesner et al.
- [The size and range effect: lifecycle greenhouse gas emissions of electric vehicles](#)
Linda Ager-Wick Ellingsen, Bhawna Singh and Anders Hammer Strømman
- [Quality research of paintwork of Volkswagen Tuareg car body elements](#)
F A Kipriyanov, R A Shushkov, A S Mikhailov et al.



ECS Membership = Connection

ECS membership connects you to the electrochemical community:

- Facilitate your research and discovery through ECS meetings which convene scientists from around the world;
- Access professional support through your lifetime career;
- Open up mentorship opportunities across the stages of your career;
- Build relationships that nurture partnership, teamwork—and success!

Join ECS!

Visit electrochem.org/join



Redesign of a Volkswagen Crafter vehicle to a hybrid vehicle having e-motor and diesel engine

Sándor Bodzás¹, Zsolt Tiba², Piroska Ailer³, Géza Husi⁴

¹deputy head of department, associate professor

Department of Mechanical Engineering, Faculty of Engineering, University of Debrecen, Hungary

²collage professor, Department of Air- and Load Vehicle, Faculty of Engineering, University of Debrecen, Hungary

³vice rector, collage professor, Department of Air- and Load Vehicle, Faculty of Engineering, University of Debrecen, Hungary

⁴dean, head of department, associate professor, Department of Air- and Load Vehicle, Faculty of Engineering, University of Debrecen, Hungary

¹bodzassandor@eng.unideb.hu, ²tiba@eng.unideb.hu, ³ailer.piroska@unideb.hu,

⁴husigeza@eng.unideb.hu

Abstract

The aim of this study is to show the results of the vehicle research group redesigned a Volkswagen Crafter diesel type van to a multi hybrid vehicle.

The original chassis of the four-wheel drive van provides the base of the vehicle. The electric motor and the gearbox designed by the research group is placed in front of the rear suspension. This electric drive unit is coupled to the rear differential via the Haldex clutch. During the electric drive the transaxle of the van is in neutral gear and the diesel engine is not operating. Releasing the Haldex clutch the electric drive is detached from the vehicle and the diesel engine is activated to drive the front-wheels. Our purpose is to test the electric drive of the vehicle by conducting measurements on the electric motor and the battery, this way making new research directions.

1. Introduction

The Volkswagen Crafter (Figure 1), the first appearance is in 2006, has 3 to 5 ton mess in the largest case. The German car manufacturer, Volkswagen Commercial Vehicles, manufactured this brand. Originally, this type changed the Volkswagen Transporter LT nameplate first launched in 1975. The first issue Crafter was made in the Mercedes-Benz Ludwigsfelde and Düsseldorf plants. This is the same German factory where the Mercedes-Benz Sprinter is manufactured and assembled. A French car designer Laurent Boulay is responsible for the frontal design of the Crafter, which takes advice from the Volkswagen Constellation [1].

All the internal combustion engines were based upon Volkswagen Group's reengineered 2.5 litre R5 TDI between 2006 and 2010. This engine is an inline-five cylinder (R5) Turbocharged Direct Injection (TDI) diesel engine. It displacement is 2,459 cm³ (150.1 cu in), and it has the latest common rail fuel system, with piezoelectric actuated injectors for the cylinder-direct fuel injection. It also use a diesel



particulate filter (DPF), permitting all engine variants to comply with Euro IV European emission standards [1].

The 2.5 TDI CR engine was redesigned in the 2010th version because the previous problems of turbo failure had to be corrected. An update on the engine was also released, under the guise of "Blue TDI", which used AdBlue - or diesel exhaust fluid (DEF) - in combination with a DPF to gain the stricter Euro V EEV European emission standards [1].

The Crafter has three wheelbase options: 3,250 mm, 3,665 mm and 4,325 mm. It is contained with front airbags as standard, and side and curtain airbags as options, along with anti-lock braking system (ABS), load adapting electronic stability programme (ESP), anti-slip regulation (ASR), and electronic differential lock (EDL).

The electronic differential lock (EDL) used by Volkswagen is not a differential lock at all. Sensors monitor both roadwheel speeds go through a driven shaft, and if one is rotating materially faster than the other the EDL system instantaneous brakes it. This potently forwards the torque to the other driven wheel that is regarded for still have grip [1].



Figure 1. The establishment of the Volkswagen Crafter [2]

The aim of our research is to insert an electric motor (e-motor) to drive the rear axes. In this case the front-wheels can be driven by the diesel engine and the rear wheels by the e-motor (Figure 2).

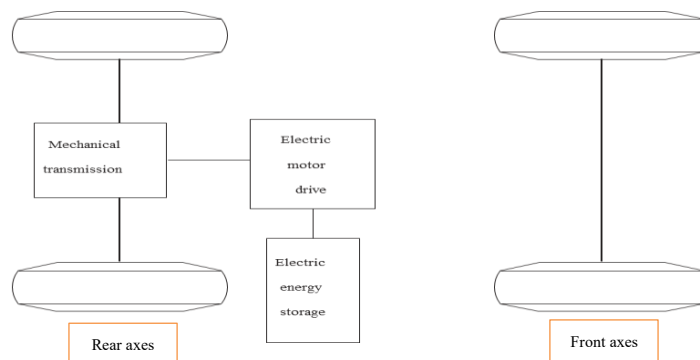

Figure 2. Integration of the e-motor

2. The assembly process and the usage of the vehicle

The vehicle can operates in two modes: diesel mode and electric mode. The required mode can be selected by a mode switch before starting the engine. During the ignition the mode switch is ineffectual.

2.1. Diesel mode

The vehicle is driven by the diesel engine. This engine follows the speed of the vehicle. It does not permit higher speed than 20 km/h.

2.2. Electric mode

The prerequisite of activating the electric mode:

- Switching on the ignition the e-drive makes a test. During this time the brake pedal has to be pressed. During the test if we do not press it or release it, the test will be interrupted and the e-drive can not be switched on. The restart can be possible based on out-in switch of the ignition switch again.
- The gearshift should be in neutral position.

2.3. Motion of the vehicle by e-mode

The forward mode is activated by the joystick moved to forward position. The middle position is the neutral. Switching back is the reverse gear. The condition of switching into forward or reverse gear is pressing the brake pedal. Switching into reverse gear is possible in case of a standing vehicle. The vehicle speed is limited for 20 km/h in e-mode.

2.4. Controlling of the e-vehicle

The Vehicle Control Unit (VCU) can get supply voltage from the ignition switch or from the charger port. The charging mode is activated if the supply voltage is received by the charger port. If it is not made, the VCU investigates the position of the mode switch. Depending of this position, diesel or electric mode will be activated.

During operating the VCU does the following inspections:

- the CAN communication between the components of the system,
- the function of the gas pedal,
- the function of transmission and number of revolution,
- the correct combination of the switching level,
- the voltage of the accumulator,
- the electric insulation by monitoring insulation resistance.

2.5. Design of a gear box for the e-mode

A new gear box was designed for a given electrical motor. The parameters of the engine are $I_{\max}=418/166$ A, $P_{\max}=82.3/53.5$ kW, $U=320$ V. The geometric parameters of the gears are on Table 1. The schematic figure and the CAD model can be seen on Figure 3 and 4.

Table 1. The initial parameters of the gears

Diameters, d [mm]	Axial module, m [mm]	Number of teeth, z	Gear ratio, i
d ₁	2.25	26	1.54
d ₂	2.25	40	
d ₃	2.5	20	3.4
d ₄	2.5	68	
d ₅	3	18	2.33
d ₆	3	42	
$\Sigma i=12.22$			

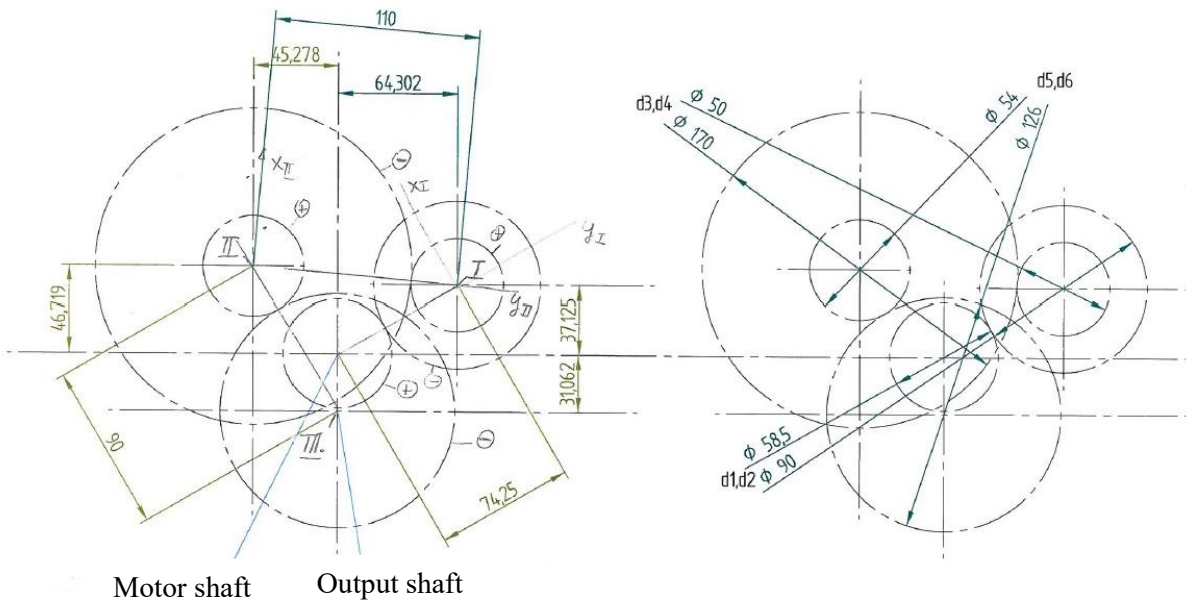

Figure 3. The arrangement of the gears into the gear box

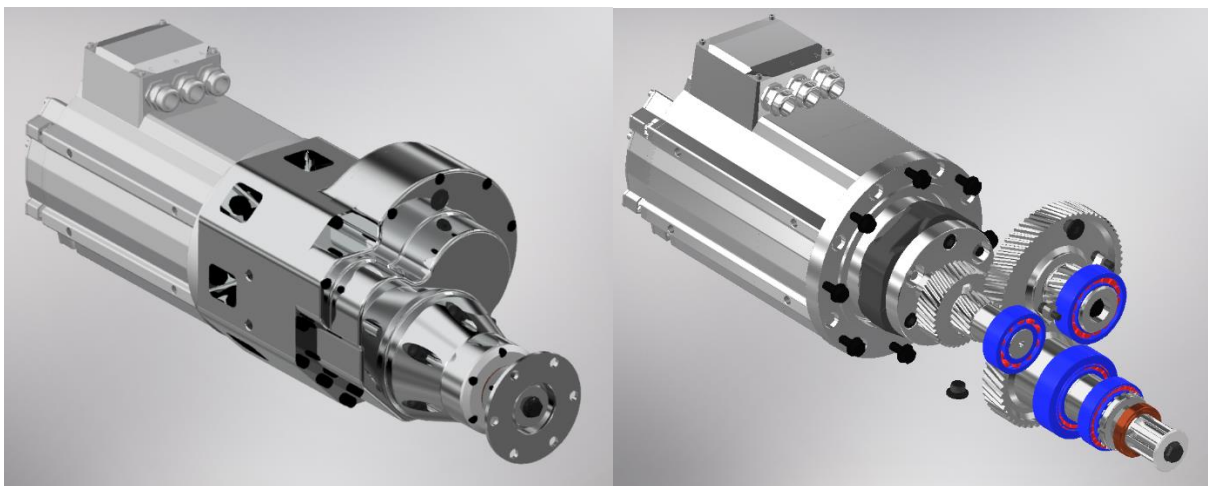

Figure 4. The simulated models of the designed gearbox

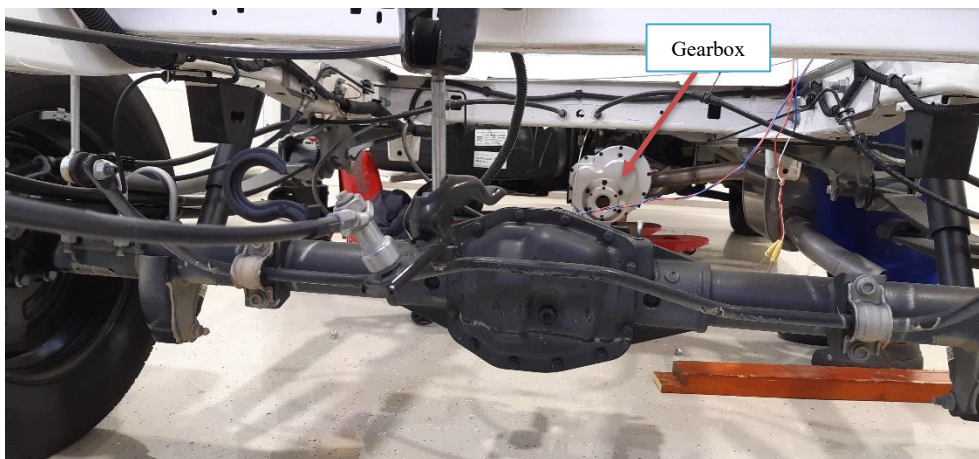

Figure 5. The position of the gearbox at the bottom of the vehicle

After the geometric design the gearbox was manufactured and assembled into the vehicle (Figure 5). The build-up of the vehicle after the conversion can be seen on Figure 6. The electric control system can be seen above the rear axle on the vehicle platform.

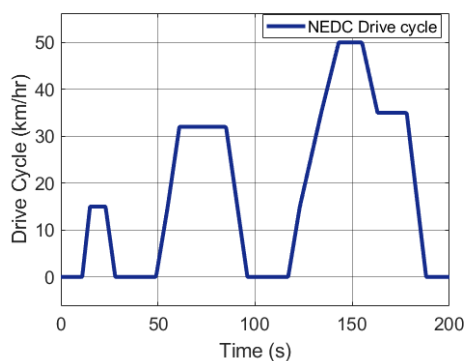

Figure 6. The build-up of the vehicle after the conversion

3. Modelling and simulation using Permanent Magnet Synchronous Motor

The usage of the Internal Combustion Engine (ICE) in conventional cars is one of the highest reason of global warming and air pollution. The emission of toxic gases is also injurious to living body. Electric drive was developed in modern electric cars to change the ICE. A rear-wheel driven electric powertrain based on a Permanent Magnet Synchronous Motor was established. It can change its front-wheel driven diesel engine in the environment of the city using of low average speeds. A Nissan Leaf battery with a nominal voltage of 360 V and a 24 kWh power was simulated due to the application as the energy source of the electric drivetrain [3].

The New European Driving Cycle was utilized in this work to estimate the electric drive. Another input parameter is the speed enhancement because of the analysis of the vehicle on different road conditions. A Proportional Integral Controller was controlled the speed of the vehicle and synchronous motor. Different driving cycles were applied to test the vehicle [3]. Some simulation results can be seen on Figure 7.



a) The speed gained by the vehicle

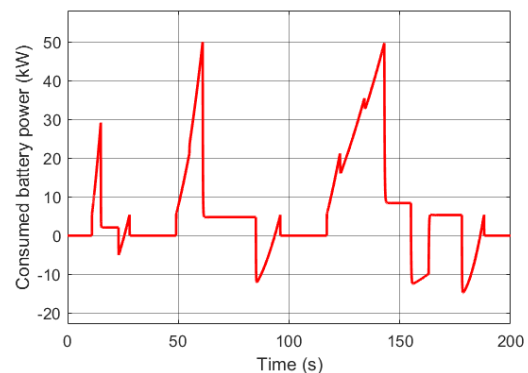

b) The power consumerism of the battery

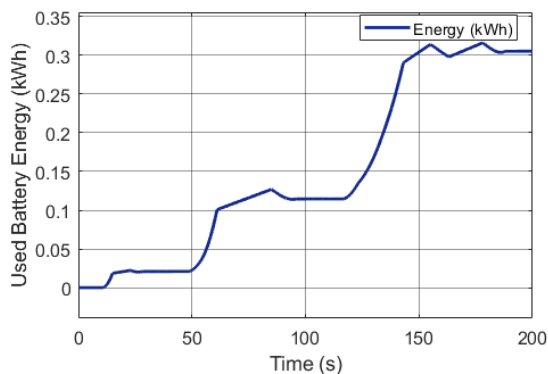

c) The energy consumerism of the battery

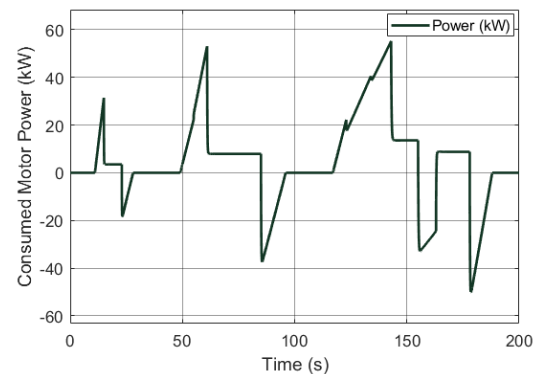

d) The power consumerism of the motor

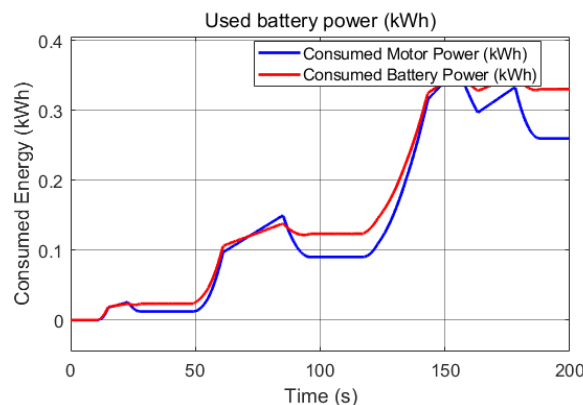

e) The energy consumerism of the motor and battery

Figure 7. The simulation results of the motor and the battery [3]

4. Conclusion

A Volkswagen Crafter diesel type vehicle was redesigned to a multi hybrid vehicle that can be operated by diesel or electric motor. The front-wheel drive is driven by the diesel engine. Switching into e-mode the rear wheel drive is activated and driven by the e-motor.

A new gearbox was designed to make a connection between the e-motor and the rear wheel drive.

A Proportional Integral Controller is used to get relation in connection with the speed of the vehicle and synchronous motor. We conducted simulations and modelling analysis to analyse the function of the e-motor and the battery under certain time.

Our purpose is to test the electric drive of the vehicle by conducting measurements on the electric motor and the battery, this way making new research directions.

Acknowledgement

Project no. TKP2020-NKA-04 has been implemented with the support provided from the **National Research, Development and Innovation Fund of Hungary**, financed under the **2020-4.1.1-TKP2020** funding scheme.

References

- [1] https://en.wikipedia.org/wiki/Volkswagen_Crafter
- [2] <https://www.truck1.eu/vans/flatbed-vans/volkswagen-crafter-2-0-tdi-143p-grijs-metalic-ac-4-a2577948.html>
- [3] **Babangida, A., Szemes, P. T.:** *Electric vehicle modelling and simulation of a light commercial vehicle using PMSM propulsion*, Hungarian Journal of Industry and Chemistry, Vol. 49(1) pp. 37–46 (2021), DOI: 10.33927/hjic-2021-06