



AKADÉMIAI KIADÓ



International Review of
Applied Sciences and
Engineering

13 (2022) 3, 263-271

DOI:

10.1556/1848.2021.00360

© 2021 The Author(s)

ORIGINAL RESEARCH
PAPER



Real-time implementation of Fuzzy Logic Controller based on chicken swarm optimization for the ball and plate system

Ahmed A. Oglah* and Mohammed Majid Msallam

Control and Systems Engineering Department, University of Technology, Iraq

Received: August 8, 2021 • Accepted: October 16, 2021

Published online: December 6, 2021

ABSTRACT

The ball and Plate (BaP) system is the typical example of the nonlinear dynamic system that is used in a wide range of engineering applications. So, many researchers in the control field are using the BaP system to check robust controllers under several points that challenge it, such as internal and external disturbances. Our manuscript proposed a position control intelligent technique with two directions (2D) for the BaP system by optimized multi Fuzzy Logic Controllers (FLC's) with Chicken Swarm Optimization (CSO) for each one. The gains and rules of the FLC's can tune based on the CSO. This proposal utilizes the ability of the FLC's to observe the position of the ball. At our work, the BaP system that belonged to Control Laboratory/Systems and Control Engineering department is used for real-time proposal implementation. The results have been showing a very good percentage enhancement in settling time, rise time, and overshoot, of the X-axis and Y-axis, respectively.

KEYWORDS

real time multi fuzzy logic controller, ball and plate system, chicken swarm optimization, embedded system

1. INTRODUCTION

BaP are electromechanical devices intended to mimic the behavior of some types of multi-variable systems. It is a typical standard for control theory research because it has characteristics of under-actuated, cascaded structure, and strong-coupling [1]. It is composed of a metallic ball that is free to roll on a flat plate due to electromechanical actuators' two-dimensional deflection. The plate must be placed on a special sort of spherical joint to allow this type of movement which usually approximates the BaP system application in the robotics field. Also, it may be a one-dimensional with ball and beam [2]. The low cost and easy implementation are the main advantages of this type of system [3]. Also, it provides the ability to experimentally test theoretical expertise in simulation, control, and other engineering fields, such as computer vision and robotics.

In the literature, Ali et al. [2] had a new approach to control the position of the ball. They used a nonlinear controller with invasive weed optimization (IWO) which is used to obtain the optimal parameters for the proposed controller. The hybrid learning algorithm which is Genetic Algorithm Fuzzy Logic Neural Network Control (GA-FNNC) was prepared by Dong et al. [4], who designed a controller for the stabilization of the BaP system. In [5], they had designed adaptive dynamic programming (ADP) based on optimal trajectory tracking controller for a BaP system and apply large-scale on it. A type-2 FLC had been designed for the stabilization of the BaP system by Farooq [6] and reference tracking of it. The controller had used plate angles as the premise variables for the scheduling of gains and a collection of linear matrix inequalities ensures its stability. The BaP with the controller was implemented in the virtual laboratory by Fabregas et al. [7]. In their work, they control the position of the ball by manipulating the inclination angles of the plate. In a manuscript published by Cheng

*Corresponding author.

E-mail: Ahmed.A.Oglah@uotechnology.edu.iq



et al. [8], their proposal was used as a visual servo control to illustrate the mechanical wrist dexterity from the standpoint of table tennis. At the first stage of their work, A BaP system had been chosen. The robotic wrist with a plate attached had been developed by two degrees of freedom. A video camera provided feedback for the control algorithm with a Linear Quadratic Regulator (LQR).

Most of the researchers use the BaP system in the control field to check the robustness of the control response because its complex dynamics depend on inherent instability and nonlinearity. This paper will be using the FLC, and the chicken swarm optimization (CSO) used to tune the I/O gains to increase the stability of the BaP system. Also, the CSO is used to find the best rules to enhance the stability of the BaP system. Our design aims to create an efficient and reliable controller that can produce signals that always force the BaP system states toward the reference states.

2. MODELING STRUCTURE

In the BaP system, which is the extension of traditional ball and beam system, the mathematical model depends on Euler Lagrange’s equation. Figure 1 shows a simple schematic representation of the BaP system. The motion of the ball will be on the x -axis and the y -axis of the plane $\{x, y\}$, while the deflection angles of the plate are represented by the rotational variables are θ and δ . The ball will move on the x -axis when the θ is slanted from the horizon. While the δ will move the ball on the y -axis when it is slanted from the horizon. The oblique of the θ and δ will be by servo motors. The controller will provide the appropriate signal to the motors that put the ball in the right place.

Ali et al. [2] derived the equation of the BaP system based on the relationship between potential energy and the kinetic influenced by the mechanical system due to its motion and the change in the structure. The BaP system is described by the following equations [2].

$$\ddot{X} = \frac{-r^2 mg}{r^2 m + J} \left(\sin \theta - \frac{X \dot{\theta}^2 + Y \dot{\theta} \dot{\delta}}{g} \right) \quad (1)$$

$$\ddot{Y} = \frac{-r^2 mg}{r^2 m + J} \left(\sin \delta - \frac{X \dot{\delta}^2 + Y \dot{\theta} \dot{\delta}}{g} \right) \quad (2)$$

The parameters and values for equations of the BaP system that use in our proposal are shown in Table 1.

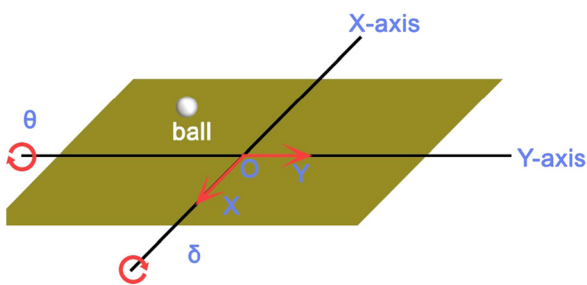

Fig. 1. The BaP system schematic

Table 1. The parameters and values of system

Parameter	Description	Value	Unit
r	Radius of Ball	0.038	m
m	Mass of Ball	0.223	Kg
g	Acceleration of Gravitational	9.81	$m\ s^{-2}$
J	Inertia Moment of Ball	$1.76e-5$	$Kg\ m^2$

3. FUZZY LOGIC CONCEPT

In 1965, Fuzzy Sets was published by Lotfi A. Zadeh [9]. Zadeh then developed the Fuzzy Logic theory, which has proven to be useful in a variety of applications, ranging from consumer to industrial intelligent goods. Fuzzy Logic is one form of intelligence used that does not require detailed mathematical modeling knowledge such as a decision in the mind of a human [10]. Fuzzy logic assigns numeric values between 0 and 1 to each suggestion to represent uncertainty. Fuzzy logic tries to solve problems using an imprecise range of data that allows for a variety of accurate conclusions to be reached. The general diagram of fuzzy logic is shown in Fig. 2. The following three steps are needed to apply fuzzy logic to a real application [11].

- Fuzzification: crisp data or classical data is converted into Membership Functions (MFs) or fuzzy data.
- Fuzzy Inference Process: membership functions are combined with the control rules to get the fuzzy output.
- Defuzzification: fuzzy control is converted into real control action or real output by using different methods to calculate each associated output that is fuzzy.

FLC is a control system that depends on fuzzy logic. In the last few years, fuzzy logic control has witnessed a lot of interest for robust performance as a controller on the system. The systems which have fuzzy logic control are more stable. A FLC is to provide stable controllers applicable to the BaP system and AQM system [12, 13]. In our proposed method, the FLC provides an action control into the BaP system. The gain of error and change error will tune based on Chicken Swarm Optimization (CSO). The rules of fuzzy logic need more experience to be written, where the CSO will tune the rules of fuzzy logic. Fig. 3 shows the FLC which is designed to provide the stability of the BaP system in our proposal.

The simulation of the BaP system has two inputs that control the movement of the ball toward an x -axis and y -axis. The FLC has two input variables, which are error and change of error and the output is action control for the x -axis or x -axis. The values of the error and change of error are in the range of -1 and 1 . The input memberships of the FLC for the error and change of error are two, which are Negative (N) and Positive (P). The output memberships of the FLC for the action control are nine, which are Negative Big (NB), Negative Medium (NM), Negative Small (NS), Zero Left (ZL), Zero Center (ZC), Zero Right (ZR), Positive Big (PB), Positive Medium (BM) and Positive Small (PS). A shape of membership of the FLC is the Gaussian membership for input and triangular for output. The



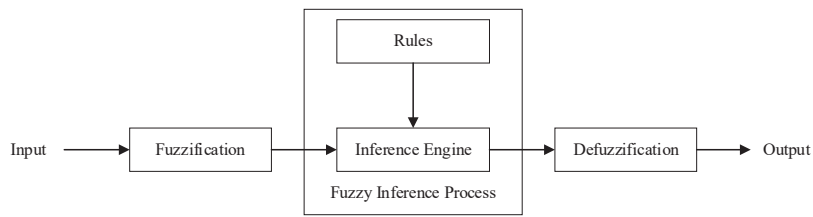

Fig. 2. General diagram of fuzzy logic

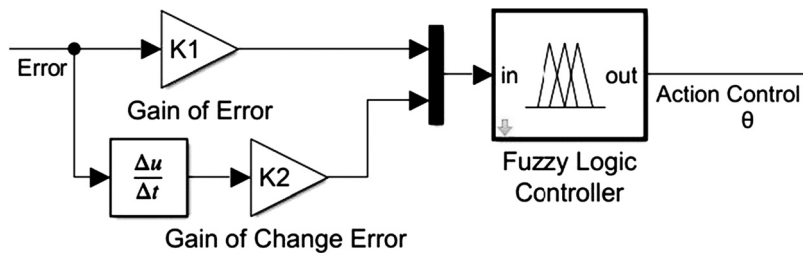

Fig. 3. The design of FLC

number of rules in our work is four, which multiply the number of input memberships. The centroid (center of gravity) and Mamdani type in the inference process are used in the Defuzzification.

4. OPTIMIZATION ALGORITHM

One of the social animals living and searching for food together in a group are chickens. The group has roosters, hens and chicks. They are cognitively sophisticated and they communicate by cackles, clucks, chirps, and cries and they behave in mating, nesting, food discovery, and danger [14].

In the social lives of chickens, a hierarchy plays a significant role. The poor will dominate the majority of chickens in a flock. There are the more dominant hens that stay close to the head roosters and the more submissive hens and roosters that are on the outskirts of the party. The dominant individuals will have priority for food, while roosters will call their group mates first to eat when they find food [15]. Gracious behavior also exists in the hens when they raise their children. In general, the behavior of chicken varies with gender. The head rooster will look for food favorably, and battle with chickens entering the area the group inhabits. This biological behavior was inspired by Meng et al. [16] to apply it as an intelligent algorithm to solve problems. The

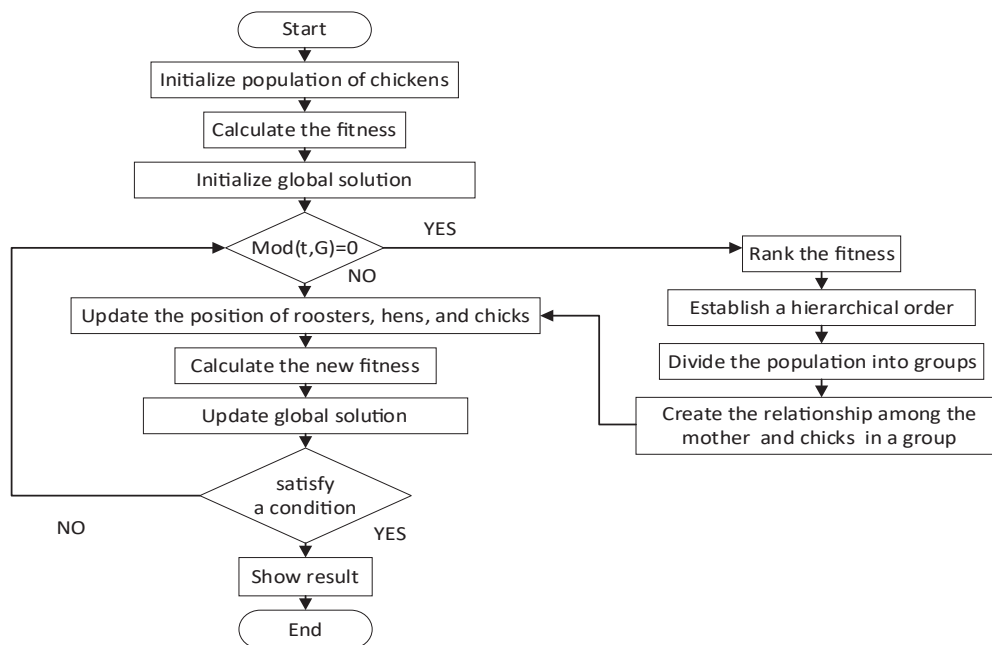
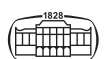

Fig. 4. Flowchart of CSO



roosters that have higher fitness values have priority for food access than the ones that have worse fitness values. The simulation of this is to consider that roosters with higher

fitness values will search for food in a wider variety of locations than roosters with lower fitness values. This can be expressed as follows [16].

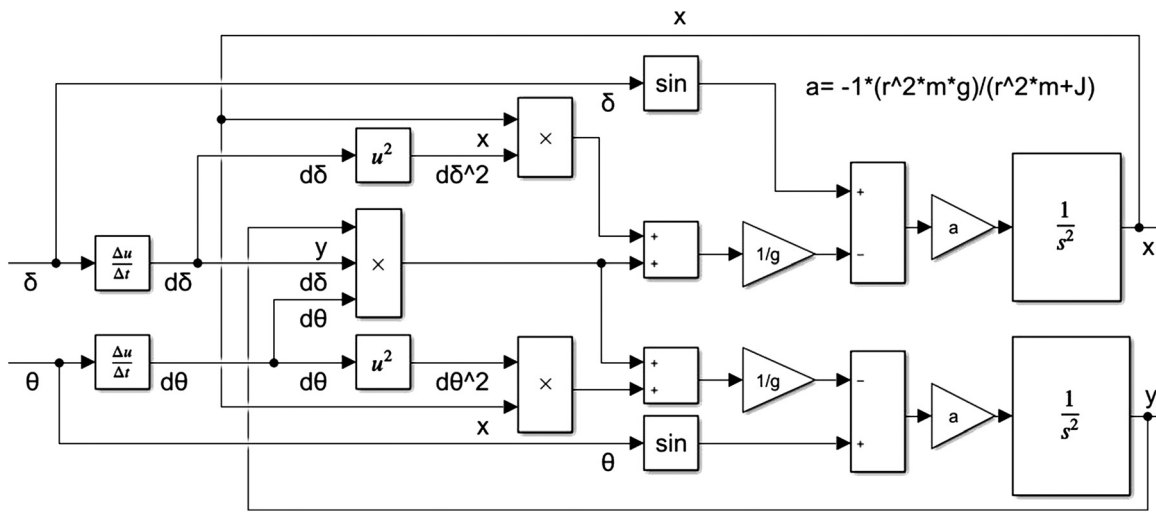

Fig. 5. Block diagram of Modeling for the BaP system

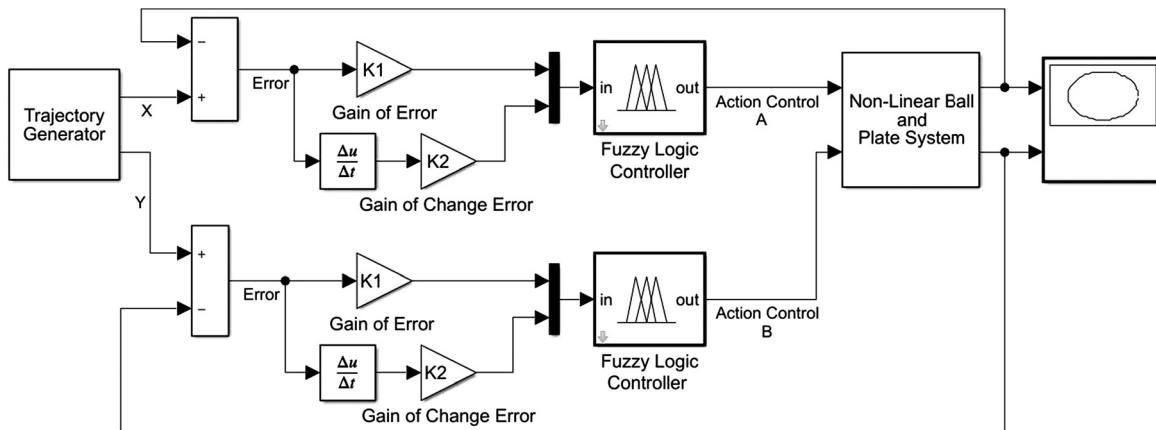

Fig. 6. Block diagram of a Fuzzy Logic Controller and the BaP system

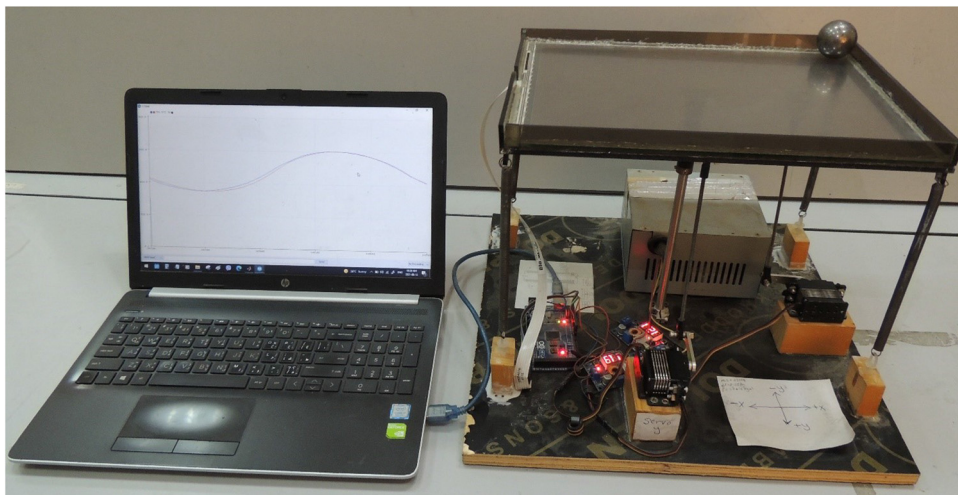

Fig. 7. The BaP system in the Controller Laboratory

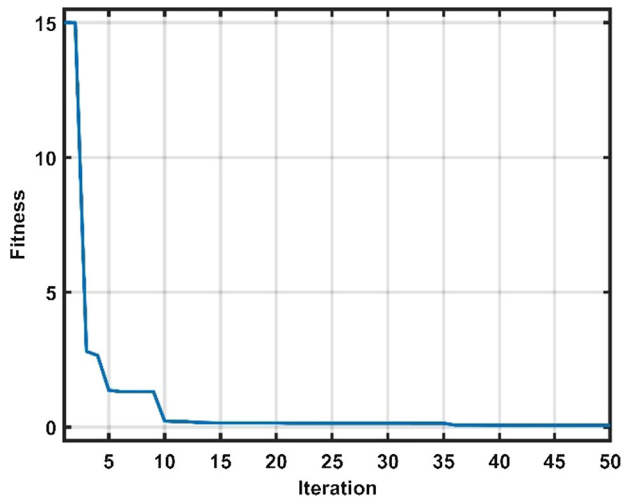

Fig. 8. Best Fitness versus iteration for CSO

$$X^{i+1} = X^i [1 + \text{Rand}(0, \sigma^2)] \tag{3}$$

$$\sigma^2 = \begin{cases} 1 & \text{if } f_j \leq f_k \\ \frac{f_k - f_j}{e^{|f_j| + \epsilon}} & \text{otherwise} \end{cases} \quad k \in [1, K], k \neq j \tag{4}$$

Where, $\text{Rand}(0, \sigma^2)$ is a Gaussian distribution with a standard deviation σ^2 of one and a mean of zero. ϵ is the minimum number constant in the computer to prevent zero division error. k is an index of the rooster which is randomly selected from the group of roosters. f is a fitness value of the matching X which is the position of the rooster.

On the other hand, the hens will hunt for food alongside their groupmate roosters. Furthermore, they would steal good food found by other chickens at random, though the other chickens repressed them. The dominant hens would have an advantage over the submissive hens when competing for food. Mathematically, it can be expressed as follows.

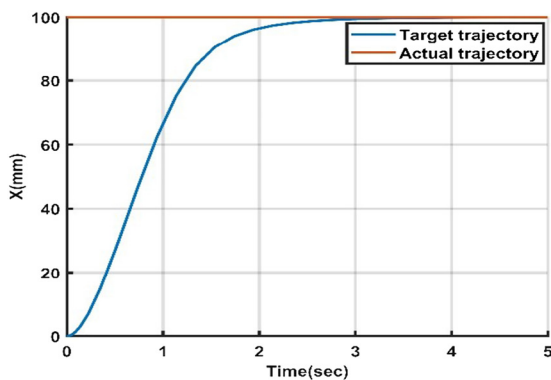

a) Response of X-axis

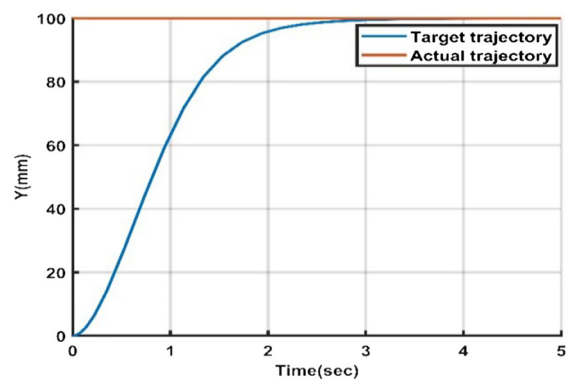

b) Response of Y-axis

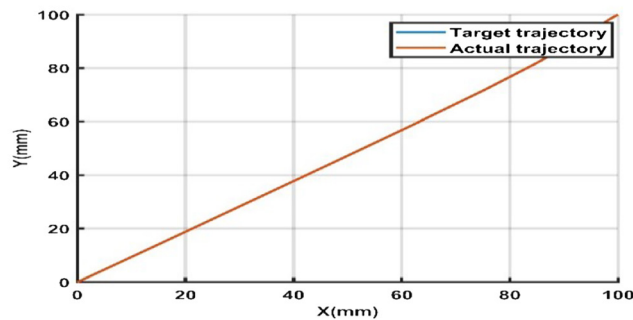

c) Response of line path

Fig. 9. Target and actual trajectories for a line path

Table 2. Line path characteristic of Proposed controllers and published work in reference [2]

Controller Characteristic	Proposed controllers Y-axis	Published work in reference [2]. Y-axis	Enhancement Efficiency in Y-axis	Proposed controllers X-axis	Published work in reference [2]. X-axis	Enhancement Efficiency in X-axis
Rise Time	1.3387	2.0753	35.4937%	1.2514	2.2165	43.5416%
Settling Time	2.3301	6.3936	63.5557%	2.2857	6.8587	66.6744%
Overshoot	0	6.4990	100%	0	6.2476	100%

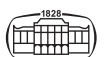

Table 3. Optimal gain parameters of proposed controllers

X-axis	K1	0.456658699380614
	K2	0.337016262939350
Y-axis	K1	0.349028015147271
	K2	0.280045644230414

$$X^{i+1} = X^i + S_1 \text{Rand}[X_{r_1}^i - X^i] + S_2 \text{Rand}[X_{r_2}^i - X^i] \quad (5)$$

$$S_1 = e^{\frac{f_j - f_{r_1}}{|f_j| + \epsilon}} \quad (6)$$

$$S_2 = e^{f_{r_2} - f_j} \quad (7)$$

Where Rand is a random number among zero and one. r_1 is the index of the rooster who is the hen's group-mate, while r_2 is the index of the rooster or hen who is selected at random from the swarm. $r_1 \neq r_2$.

$$X^{i+1} = X^i + \text{FL}[X_m^i - X^i] \quad (8)$$

Where, the X_m^i is the position of the chick's mother. FL is indicating that the chick is to follow its mother to forage for food. The parameter FL of each chick is to choose randomly between 0 and 2.

$$\text{fitness} = \sum (X_{\text{target}} - X_{\text{actual}})^2 + (Y_{\text{target}} - Y_{\text{actual}})^2 \quad (9)$$

The CSO is to tune the rules and gain the RLC based on the fitness function which is described in Eq. 9. The fitness function represents the error of the path for the ball on the plate.

5. NON LINEAR DYNAMIC MODELING: SIMULATION AND IMPLEMENTATION

At this point, the program Matlab 2018b will be used to simulate the BaP system. Moreover, FLC after tuning by CSO, will be designed. Eqs. 1 and 2 which represent the BaP system, are simulated in Simulink such as shown in Figs 4-7.

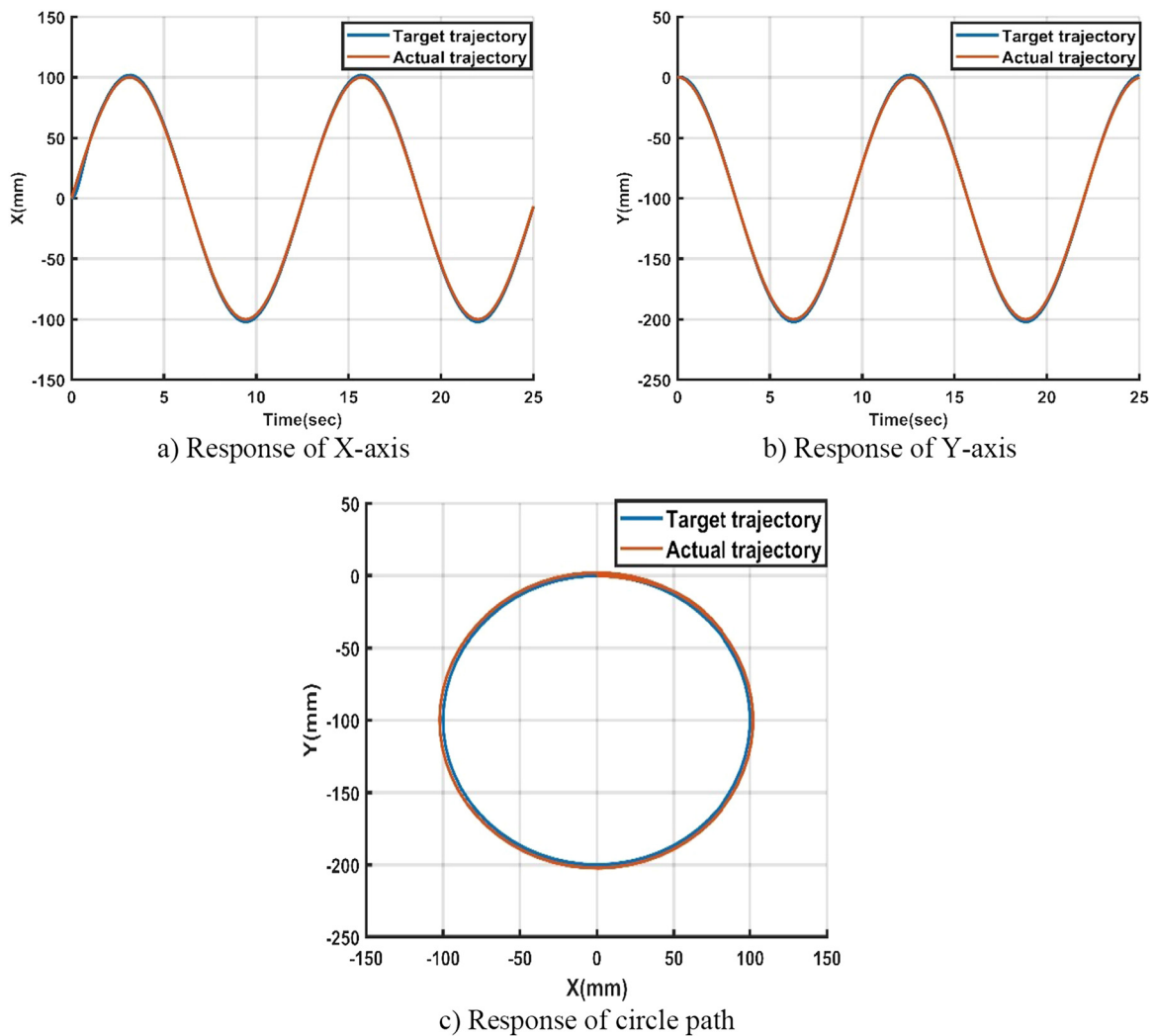

Fig. 10. Target and actual trajectories for circle path



Our proposal is implemented in the Control Laboratory/ Control and Systems Engineering Department by using the BaP system. Where the 310 and 230 mm are the width and height of the BaP system in Control Laboratory. The BaP system consists of two servo motors, a touch screen, Arduino mega, and a power supply. The touch screen is used to get coordinates of the ball. The Arduino mega receives a signal from it with noise. So, the low pass filter was used to remove the noise.

6. THE SIMULATION AND EXPERIMENTAL RESULTS

The CSO uses the fitness function to get the best I/O gains and rules for the multi fuzzy logic of the controller. Figure 8 illustrates the path of the solution. Where iteration is 50 and the best minimum value of the fitness function is (0.06173780).

The unit step is used as input to the X-axis and Y-axis of the BaP system to check a characteristics of our proposal. Figure 9 is shown target and actual trajectories for line path

responses of the BaP system. The percentage enhancement of our proposal is the best when compared with published work in reference [2] such as shown in Table 2.

Table 3 represents the gain parameters of the proposed controller which was founded by using the optimization technique (CSO).

Another experiment is applied on the BaP system with a circular path to demonstrate the effectiveness of the proposed control method. The sine wave form is used as input to the X-axis while the cos is used as input to the Y-axis of the BaP system. The sine and cos wave form have the same frequency to generate the circular path in which the ball moves it. The path of the ball is exactly on the target trajectory such as shown in Fig. 10.

When the sine and cos wave form do not have the same frequency, the infinite path had generated in which the ball moves in such a way as shown in Fig. 11.

The efficiency of our proposal is clear when the square path has been generated in which the ball moves in such a way as shown in Fig. 12.

Finally, the results of the practical experiment had been collected from Embedded system like Arduino mega and drawn in Fig. 13. The practical results in our proposal

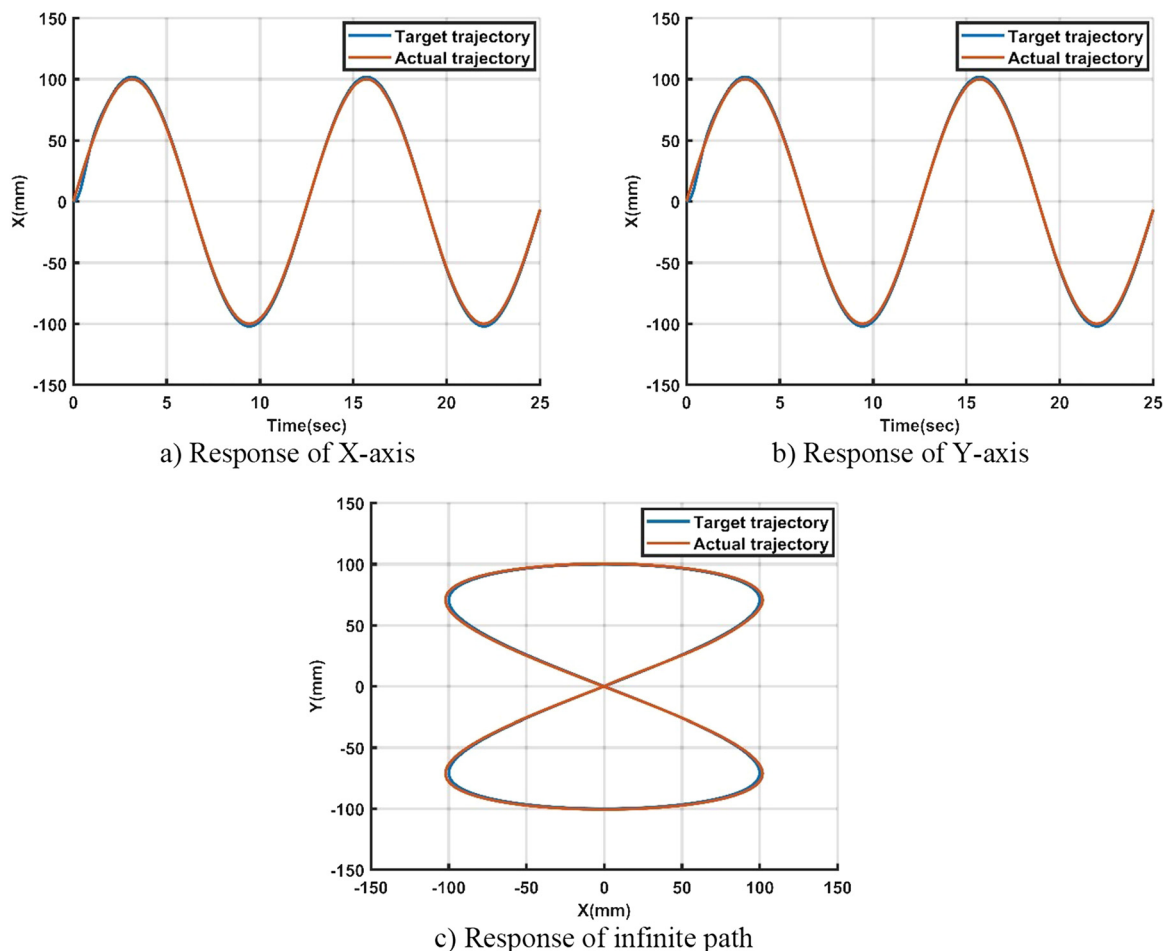

Fig. 11. Target and actual trajectories for infinite path

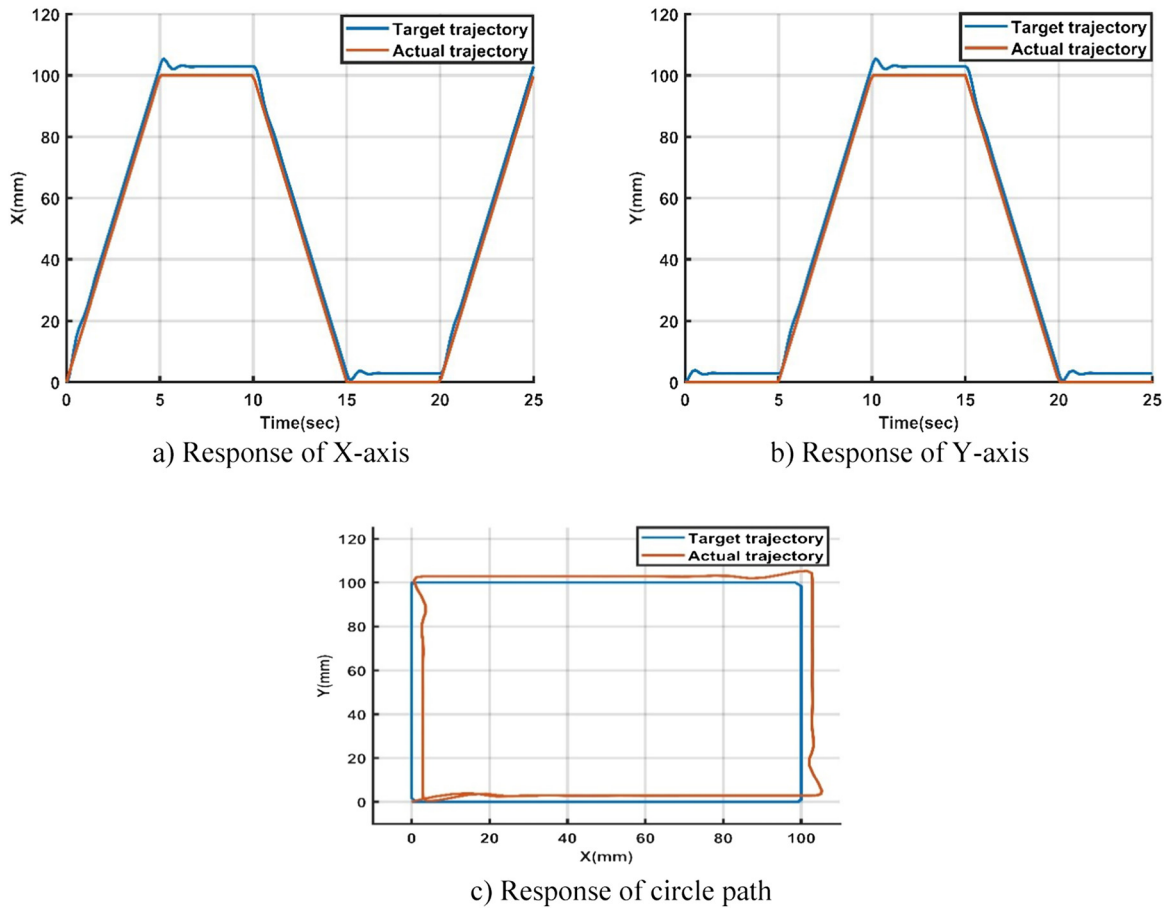

Fig. 12. Target and actual trajectories for square path

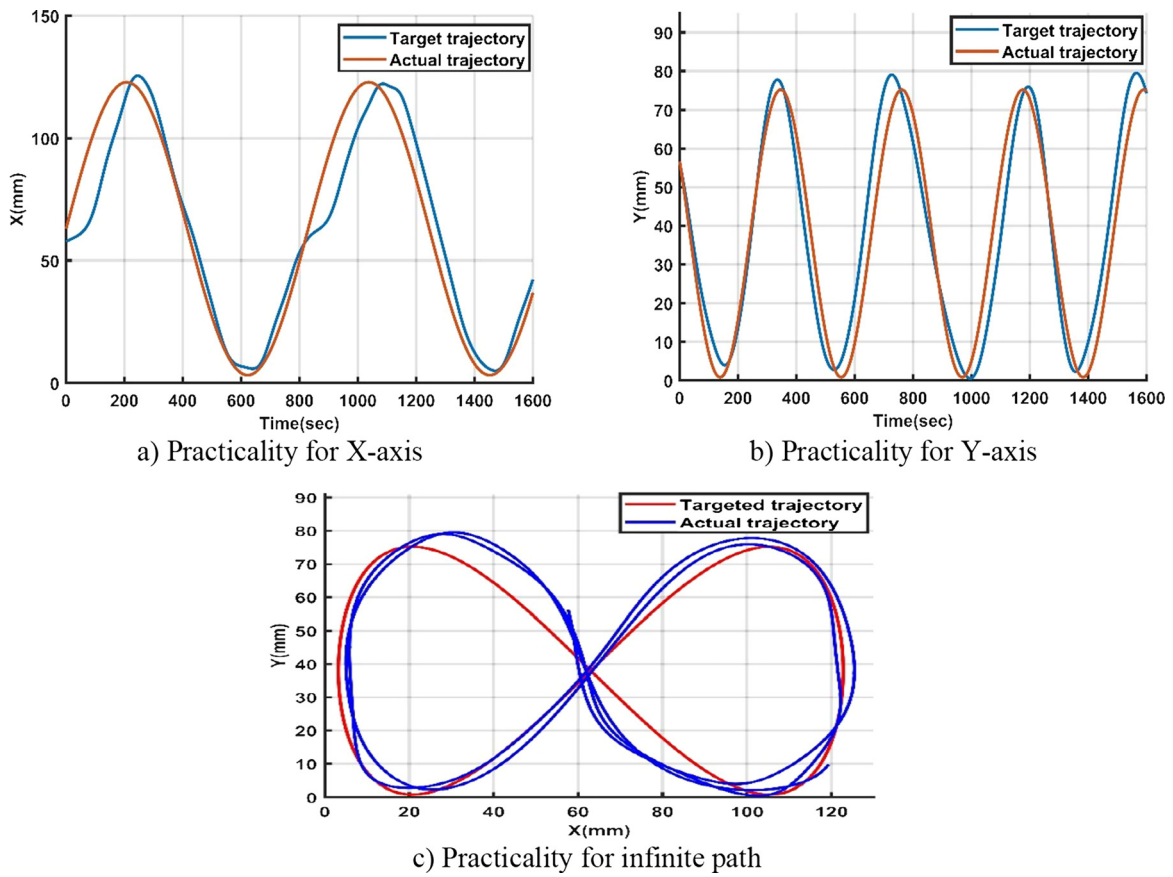

Fig. 13. Target and actual trajectories obtained practically



demonstrate the controller characteristics robustness with optimized I/O gains and rules for the BaP system which had tuned in the CSO.

7. CONCLUSIONS

In this work, the MFLC's have been proposed to control the path of a ball in the (2D) BaP system. The nonlinear dynamics equations of the BaP system have been simulated in Simulink of Matlab to tune the parameter of the MFLC's by CSO. Many states of targeted trajectory have been simulated and implemented to test and validate the designed controllers. Rise time, settling time, and overshoot, for the results of the simulation were (1.3339 s, 2.3445 s and zero), respectively. The Laboratory BaP system has been used to test/implement MFLC's design and obtained practical results that are very close to simulation results. The practical part is implemented by using two very robust controllers that lead two servo motors in the X-axis and Y-axis. The big challenge scenario in future work will be using one central servo DC motor for both axes to control it.

REFERENCES

- [1] M. Jie, H. Tao, and J. Huang, "Observer integrated backstepping control for a BaP system," *Int. J. Dyn. Control*, pp. 1–8, 2020.
- [2] H.I. Ali, H.M. Jassim, and A.F. Hasan, "Optimal nonlinear model reference controller design for BaP system," *Arabian J. Sci. Eng.*, vol. 44, no. 8, pp. 6757–68, 2019.
- [3] D. Núñez, G. Acosta, and J. Jiménez, "Control of a ball-and-plate system using a State-feedback controller," *Ingeniare: Revista Chilena de Ingeniería*, vol. 28, no. 1, pp. 6–15, 2020.
- [4] X. Dong, Z. Zhang, and J. Tao, "Design of fuzzy logic neural network controller optimized by GA for BaP system," in 2009 Sixth International Conference on Fuzzy logic Systems and Knowledge Discovery, vol. 4, IEEE, 2009.
- [5] F. Köpf, S. Kille, J. Inga, and S. Hohmann, "Adaptive optimal trajectory tracking control applied to a large-scale ball-on-plate system," arXiv preprint arXiv:2010.13486, 2020.
- [6] U. Farooq, J. Gu, and J. Luo, "On the interval type-2 fuzzy logic control of BaP system," in 2013 IEEE International Conference on Robotics and Biomimetics (ROBIO), IEEE, 2013.
- [7] E. Fabregas, et al., "Virtual laboratory of the BaP system," *IFAC-PapersOnLine*, vol. 48, no. 29, pp. 152–7, 2015.
- [8] C.-C. Cheng and C.-H. Tsai, "Visual servo control for balancing a ball-plate system," *Int. J. Mech. Eng. Robotics Res.*, vol. 5, no. 1, p. 28, 2016.
- [9] I. Dzitac, F.G. Filip, and M.-J. Manolescu, "Fuzzy logic is not fuzzy: world-renowned computer scientist Lotfi A. Zadeh," *Int. J. Comput. Commun. Control*, vol. 12, no. 6, pp. 748–89, 2017.
- [10] R.S. Salman and A.T. Abdulsadda, "Network scheduling by using expert nonlinear controller," 2020.
- [11] B.P. Ganthia and K. Rout, "Deregulated power system based study of agc using pid and FLC," *Int. J. Adv. Res.*, vol. 4, no. 06, 2016.
- [12] R. Moezzi, V.T. Minh, and M. Tamre, "Fuzzy logic control for a ball and beam system: fuzzy logic control for a ball and beam system," *Int. J. Innovative Technol. Interdiscip. Sci.*, vol. 1, no. 1, pp. 39–48, 2018.
- [13] H.M. Kadhim and A.A. Oglah, "Interval type-2 and type-1fuzzy logic controllers for congestion avoidance in internet routers," *IOP Conf. Ser. Mater. Sci. Eng.*, vol. 881, August 2020, Paper no. 012135.
- [14] S. Deb, et al., "Recent studies on chicken swarm optimization algorithm: a review (2014–2018)," *Artif. Intelligence Rev.*, pp. 1–29, 2019.
- [15] D. Wu, S. Xu, and F. Kong, "Convergence analysis and improvement of the chicken swarm optimization algorithm," *IEEE Access*, vol. 4, pp. 9400–12, 2016.
- [16] X. Meng, et al., "A new bio-inspired algorithm: chicken swarm optimization," in International Conference in Swarm Intelligence, Springer, Cham, 2014.

