The image is a book cover for 'Accessible built environment' by Prof. Dr. András Zöld. The top half features a dark, textured background with a faint, repeating pattern of a person's face and a wheelchair. The title and author's name are printed in white serif font. The middle section is a photograph of a modern building interior, showing a curved concrete staircase with a metal handrail and a hallway with a polished floor. The bottom section has a dark background with the department name in white serif font.

Prof. Dr. András Zöld
Accessible built
environment

Department of Building Services
and Building Engineering

UNIVERSITY OF DEBRECEN
FACULTY OF ENGINEERING
DEPARTMENT OF BUILDING SERVICES
AND BUILDING ENGINEERING

Prof. Dr. András Zöld

ACCESSIBLE BUILT ENVIRONMENT



Debreceni Egyetemi Kiadó
Debrecen University Press
2019

Lektor:
Dr. Laki Tamás

© Debreceni Egyetemi Kiadó Debrecen University Press,
beleértve az egyetemi hálózaton belüli elektronikus terjesztés jogát is



ISBN 978-963-318-774-6

Kiadta: a Debreceni Egyetemi Kiadó Debrecen University Press
Felelős kiadó: Karácsony Gyöngyi
Nyomdai munkálatokat
a Debreceni Egyetem sokszorosítóüzeme végezte 2019-ben
<https://dupress.unideb.hu>

Contents

1. Preface.....	5
2. Assistive devices	7
2.1. Manual wheelchairs	7
2.2. Electric wheelchairs.....	9
2.3. Walking frames	11
2.4. Hoists.....	11
3. Moving in wheelchair.....	13
3.1. Moving in wheelchair on horizontal plane	13
3.2. Doors, gates.....	14
4. Ramps.....	20
4.1. Moving in wheelchair on ramps.....	20
4.2. Handrails.....	24
5. Home.....	26
5.1. Spatial limit of manipulation from wheelchair	26
5.2. Entering the building.....	27
5.3. Cupboard and shelves	28
5.4. Bed and seat.....	30
5.5. Kitchen.....	32
5.6. Window	35
6. Bath and WC.....	37
6.1. WC, bidet.....	37
6.2. Grab bars.....	40
6.3. Washbasin	42
6.4. Shower, bath-tube.....	44
6.5. Accessories.....	46
6.6. General arrangement.....	47
7. Public and commercial buildings.....	50
7.1. Entering the building.....	50
7.2. Moving in the building.....	53
7.3. Employees	55
7.4. Self-service areas.....	56

7.5. Shops.....	57
8. Visual and tactile information	61
8.1. Amplified visual information.....	61
8.2. Orientation of blind people	64
8.3. Tactile floor covering.....	67
8.4. Other types of tactile marking.....	71
9. Safety in use, emergency evacuation.....	74
9.1. Basic considerations.....	74
9.2. Escape routes	76
9.3. Doors on escape routes	79
9.4. Evacuation chair.....	81
10. Outdoor environment	82
10.1. Sidewalks.....	82
10.2 Street furniture	85
10.3 Kerb ramps	86
10.4. Pedestrian crossings.....	87
10.5. Parking	90
11. Public transport.....	93
11.1. Trams	93
11.2. Bus.....	94
11.3. Coach.....	96
11.4. Train	97
11.5. Taxi	99

1. Preface

This textbook aims at the introduction of basic aspects of “universal design”, in other term “design for all”. The matter of this concept is that the built environment must be barrier-free for everybody, disregarding the age, the physical or mental conditions. Everyone should be able to exercise his or her rights and obligations as a citizen independently and on equal terms. Everyone should therefore be able to move around in society, work, make use of products and services available to the general public, participate in cultural life, social debate and club life and have the opportunity of creating a good and active life both at home and during leisure time. However, for many disabled and elderly people it may often be difficult or impossible to get to, gain access to, find their way and move around in the premises where such activities take place. Barriers to accessibility are not recognised by the majority – say 92-94% - but prove insurmountable to people with disabilities – the remaining 6-8% of the population.

Disability may be the consequence of illness or accident, may be temporarily or constant. Nevertheless the category is much wider: sooner or later everyone will have to face these problems by just reaching old age or ‘hopefully not’ by a tragic accident. Descending abilities of elderly people in movement, hearing or sight result in step by step intensifying general disability. So a very small obstacle today can be our biggest problem tomorrow. The problem of elderly people is serious since the society is advancing in age as illustrate the statistic forecast.

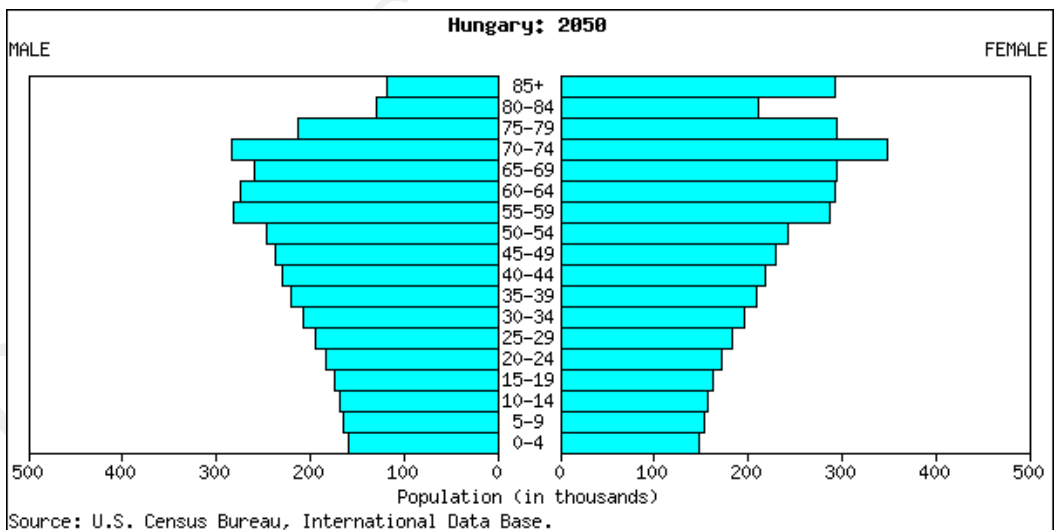

1.1. Expected distribution of citizens by gender and age

The category of people concerned with accessibility should be extended by those who carry or push heavy luggage, push a pram or a bicycle. This is why it can be

declared that according to the basic philosophy “what is indispensable for a disabled person is beneficial for the others”.

Universal design has some simple rules presented in this textbook however nothing is more important than the empathy and the logic way of thinking – these are to be considered by architects, designers and each interested stakeholders.

Consideration of the concept of universal design fulfils not only the expectation of elderly and disabled people: it results in properties being built which require only minor adaptations for a succession of owners/residents, rather than costly and disruptive major adaptations.

The pictures and drawings in this textbook are mostly taken from the AWARD DVD, the output of the Leonardo project (07/0227-L/LLP-LdV-TOI-2007-HU-001), the coordinator of the project, the co-author and editor of the DVD being identical with the author of this textbook.

It is to be emphasized that the rules and design data, presented in this textbook are of general validity based on anthropometry, engineering approach and experience of organisations of disabled people. It can be considered as a collection of best practice examples inspiring empathic and responsible way of thinking. Nevertheless the textbook does not substitute national regulations which might be different country by country.

2. Assistive devices

Disabled persons use different devices which facilitate or make easier their motion. The most robust devices determine many space requirements in the built environment.

2.1. Manual wheelchairs

Main types of manual wheelchairs:

Standard (average manoeuvrability, average demand from the user).

Active (good manoeuvrability, higher demands from the user).

Therapeutic (for users with serious conditions regarding physical strength and ability to move).

From other aspects wheelchairs can also be classified according to their frames: they can be *fixed* frame and *folding* frame wheelchairs (which can be transported on vehicles more easily, as "luggage").

The typical design of a *standard* wheelchair is shown in the following picture:

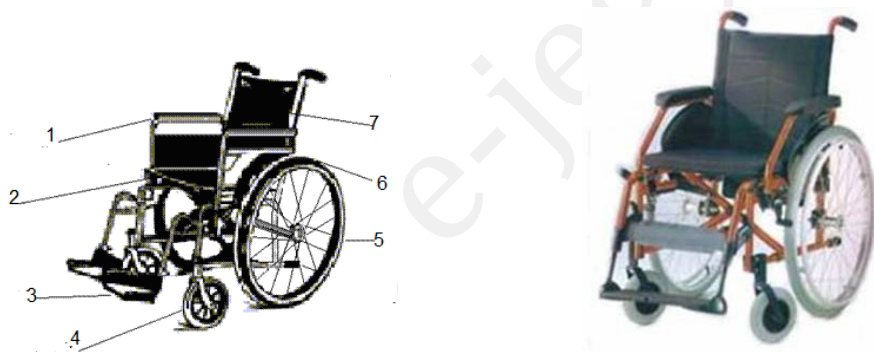

2.1. Elements and photo of standard manual wheelchair

- 1 - Swing-away padded armrest 2 - Seat cushion 3 - Swing-away foot rest 4 - Pneumatic tyre
5 - Aluminium handrim 6 - Caster 7 - Backrest

They are usually steel framed wheelchairs, with high loadability. Standard features include: normal, 40 cm high back support, 41 cm deep seat, footrest with adjustable height, parking brake, normal sized 24" (61 cm) pneumatic winding wheel with aluminium and steel hand rims, and 200 x 50 mm-pneumatic rubber casters. The weight of standard designs is between 18 -20 kg, depending on the width. They can be fitted with full-length, inclined or desk-length armrests (for ease of access to desks.). Rolling features and manoeuvrability depend on the setting: the position of the centre of gravity depends on the position of the rear wheels. *Adaptive* wheelchair is shown in Fig.2.2. The lightweight aluminium alloy, ergonomic wheelchair represents a half-way design between standard and active types. The telescopic front and rear elements of the strengthened frame enable adjustment of

the seat depth. Standard features usually include: casters with adjustable-angle axles, and rear wheels with adjustable height, which can be removed with one touch (patent-axle). The cushion and the back support are made of strong polyester. The tyres can be ordered in different sizes (front 6", 7", 8", - in cm 15,2, 17,8, 20,3 - back 22" and 24" - in cm 55,9 and 61) and types. Various armrests are also available (desk-length, inclined, full-length, or even flip-up with clothing guards). The frame of the back support is available in a straight or curved (lumbar) design - which follows the spinal curvature. The overall weight is about 15 kg, but without the rear wheels, armrest, and footrest about 9 kg. The total width, including clothing guards, in folded form is only 28 cm and with armrest 32 cm, therefore it can easily be put into a car behind the driver's seat.



2.2. Adaptive wheelchair



2.3. Active wheelchair

Active wheelchair is shown in Fig. 2.3. The frame of the active wheelchairs is made of extremely lightweight alloy. The light weight and the deep sitting position enable a quick start and excellent turning manoeuvrability; therefore it is suitable for sport activities. The adjustment of the centre of gravity is a simple operation, and doesn't affect the very ergonomically appropriate knee bend. The hand rims are usually made in size 24", 25", and 26" (61 cm, 63.6 cm and 66 cm), depending on the size of the user; the aluminium tyre casters are usually made in size 4", 5" and 6" (10.1 cm, 12.7 cm). As a result of the special front frame, the first height position of the seat can easily be set, even if the user is sitting in the wheelchair.



2.4. Therapeutic wheelchair

Therapeutic wheelchairs are usually

towed by an assistant person. The adjustment of the seat height between 39 - 52 cm is smooth due to the built-in wheel fixing adapter. The seat width can be adjusted between 38-45 or 46-53 cm depending on the frame type, by moving the hand support. The anatomically shaped 44 cm high support can smoothly be adjusted between 8° and 35° (gas spring operated), its width is 41 or 48 cm, depending on the frame type. The seat depth (depending on the position of the back support) can be adjusted between 42 and 51 cm. The wheelchair can be loaded with the weight of 130 kg, but its unladen weight is only 22-25 kg, depending on the accessories. The overall length, including the footrest, is 118 cm; the height is between 90 and 110 cm. It can be ordered with normal 24" (61 cm) and transit 12" (30,5 cm) wheels, the latter is fitted with drumbrakes. The therapeutic wheelchair can be equipped with different accessories: headrest extension with additional support from both sides, back support extension, lumbar support with shaped sides adjustable in pairs, table, glass holder..... The typical design is shown in the picture (Fig. 2.4.)

This equipment, designed for children, is the combination of wheelchairs and prams

2.2. Electric wheelchairs

The overall weight of an electric wheelchair is about 85 kg, depending on the design; the loading capacity is 130 kg + 10 kg luggage. The driving wheels are 12" (30,5 cm) and the planet wheels 9"(22,9 cm). The wheelchairs are fitted with traffic safety equipment (lights, indicator, warning triangle and horn) and with 40-50 Ah capacity batteries, which make them suitable for road traffic. Mobility features and the sensitivity of the joystick can be set by a programmable electric control panel, according to the form and degree of disability. Setting is performed by easily operated buttons and clear symbols.

The seat width, between 38 and 48 (50) cm, can be set with the help of side supports, the seat depth can be adjusted between 29 and 47 cm, depending on the position of the back support. The back support of standard designs can be reclined up to 30 degrees (optionally: with gas springs up to 30 degrees, electrically up to 60 degrees). The height of the armrests is between 18-25 cm and the position of the control box can be chosen. Footrests are available: in normal position adjustable and also in elevating angle-adjustable (specified) designs. Mobility features and the sensitivity of the joystick can be set by a programmable control panel, according to the form and degree of disability. Setting is performed by easily operated buttons and clear symbols.

During transportation the back support and the armrest can be bent down. There are electric wheelchairs with reclining seat within a broad range (-10 - +50 degrees), suitable for therapeutic purposes.



2.5. Electric wheelchair



2.6. Electric wheelchair for street traffic

Fig.2.5. shows a universal electric power operated wheelchair mainly for outdoor use. As a result of the front wheel-drive mounted with differential unit and the servo steering of the rear wheels it is perfect for outdoor use. Track stability is excellent both on uneven roads and slopes. The optimal diameter of the wheels enables the user to overcome obstacles (100 mm, for example kerbs) without difficulty. Straight running and safety in use are assured by the driving-gear mounted with shock absorption and differential gear, and also by the individually suspended and damped controlled wheels. The drive is provided by a 500 - 700 W rated power, permanent magnet, readjusting, direct current motor. The state of the battery capacity is shown by LED indicators. A wide range of additional facilities can be fitted (e.g. electric seat tilt, chin steering, finger steering, electric footrest elevation, complementary loud horn, brake indicator etc.) Several solutions, to be used in different situations, can be programmed in advance. In order to provide better handling, the button of the joystick can be substituted with fork, mushroom, or other different special handles. The wheelchair is fitted with lights, indicator, warning triangle and drum brakes. The speed limit can be 6 kmph, 10 kmph and 15 kmph. Standard features include: fix-installation footrest with adjustable height and padded, height-adjustable armrests, mounted on the side supports. The controls and the joystick can be installed on the right as well as on the left hand side.

Standing position is important not only for work activities, but also to maintain good circulation and avoid pressure sores (decubitus, ulcers). Apart from frames, suitable for these purposes, there are wheelchairs (operated by hydraulic or electric engines), which enable the user to move from seated position to a standing position and back. There are wheelchairs which enable users to reach objects placed at heights. These can work on different principles. The highest technology is represented by wheelchairs working on gyroscopic principle or providing stair climbing function.

2.3. Walking frames

Nowadays, traditional walking frames are more and more replaced by wheeled walkers (rollators) with four, rarely three wheels and equipped with shopping baskets, parking brakes and in most cases with seats.



2.7. Walking frame



2.8. Rollator

2.4. Hoists

Lifting mechanisms are used mainly in hospitals and institutes however they occur in adapted barrier free flats of seriously impaired people. Point lifts are usually used above beds, bath tubs or WC (Fig.2.9.). The point-like lifts can only be used for vertical movements. If they are not fixed to a pole, they must be installed on the ceiling.



2.9. Point lift

Lifting mechanisms, in addition to vertical movement, can be suitable for horizontal movement, too. Depending on the options and extent of transfer provided, lifts are classified as: point lifts, lifts moving on curved tracks and lifts enabling straight-line movement. The patients to be lifted are fastened with slings or a net to the hook of the lift.

By fixing the rails to the ceiling any kind of track can be built. Tracks can include bends with relatively small radii

The most common destinations within homes are the bed and the bathroom. Batteries of the



2.10. The crab can be moved on curved track

crab are recharged in the parking position with sensors placed at the destinations. The system can be operated by the user, with the help of a remote control or by sounds. The track can be led through the doorway. When a continuous track is not possible, either for structural reasons or because of the distance between the ceiling and the upper edge of the frame, the track can consist of separate sections. The track ends at the door and with the help of a double sling system the transported person is transferred onto the crab on the other side of the door. He/she is slightly lifted, the slings tied to the crab on this side of the door loosen, so they can be unhooked and the transportation continues by the other crab.

3. Moving in wheelchair

3.1. Moving in wheelchair on horizontal plane

The size and manoeuvres of wheelchairs determine the space requirements. Depending on the expected traffic (residential building, public building, railway station...) the width of the traffic path is shown in Fig. 3.11.

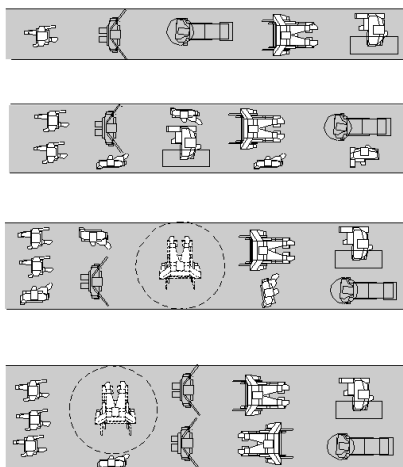

3.11. Space requirement for moving ahead in wheelchair

A minimum width of 0.9m is required to allow most wheelchair users to move conveniently ahead. This width will also suit a person using a walking frame or crutches. However, this is not wide enough to allow a wheelchair user to turn into a doorway, around a corner or to perform a u-turn. The necessary width facilitating the passing of two wheelchairs is the double.

Changing the direction or turning require more space. Nevertheless the space requirement depends on the height. Maximum circle is at the height of the foot-rest, the next one at the arms as shown in Fig. 3.11. Certainly in a corridor or on a pedestrian route it is not important, however in a bathroom or in flats, offices some area can be conserved and the use of a wash-basin or a cupboard is more comfortable if the furniture is “foot-free” (the feet are below the furniture). Similar concept is the “leg-free” form where the knee and the leg are below the wash-basin, desk, and counter.

The turning requires a circle of minimum 150 cm for manual and 170 cm for electric wheelchair. If the user is passive and an assistant should be considered, extra 30-40 cm is to be added to the maximum of the diameter at each height.



3.12. The maximum diameter of turning is at the height of the foot-rest

3.2. Doors, gates

No matter how well designed and installed, doors are to some extent barriers to free movement into and around building. However, doors are required for protection from the elements, noise control, security, privacy and fire safety reasons. Therefore the first principle in deciding on the installation of a door is to consider whether it is actually necessary.

Matters which must be considered for a person approaching a doorway are changes in level, obstructions and recognition of the door. There must be no obstructions causing a danger or hindrance to the person approaching the doorway.

A person should be able to recognise a doorway whether he or she is approaching a building or is inside the building. Contrasting colours (wall vs. frame, frame vs. leave, leave vs. lever - make, see examples in chapter 8.) make easier to find the door.

Matters which must be considered for a person addressing a doorway are the need for horizontal level area in front of the door, large enough to make a U turn, signage related to using the door, equipment used to assist in gaining entry, lighting at the doorway and the need for protection from the weather.



3.13. Possibility of communication at the entrance gate must be provided

Signage related to the use of a doorway is usual. Some signs provide occupier information (e.g. name plate, house number); others give instructions on gaining entry through the doorway (e.g. push or pull, opening times, use of intercom). Signage should be positioned where it can be accessed by a person in a wheelchair and should be of a form understandable by a person with impaired vision. The use of Braille alphabet and raised lettering should be considered.

Some doors have equipment which is intended to assist those wishing to gain entry, such as an entry phone (or intercom) or a bell, buzzer or knocker.

These must be positioned at a height suitable for all users. Between 0.9m and 1.1m above floor level is recommended.

Where a bell, buzzer or knocker is provided to alert the occupier, the possibility of the occupier having impaired hearing must be considered. A visual alert, in addition to the sound alert can be provided.

Where an entry phone is provided, alternative provision should be made for people with impaired hearing. A method of communicating by text should be considered.

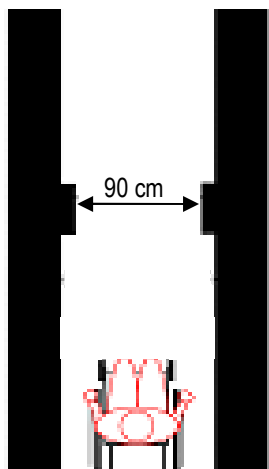

3.14. Clear width

Often people are required to wait at an entrance to a building while the door is being Protection from the weather, in the form of a canopy or recessed entrance, should be provided in such cases in non-domestic buildings.

It is recommended that the minimum effective clear width for doors is 90 cm. This width is enough for moving ahead only! Nevertheless if there is a door in the opening wider route must be provided in front of the door and behind it for opening and closing manoeuvres, depending on the type of the door. The clear width should be measured from the doorframe or doorstop, to the face of the door, although protruding door furniture may reduce the usable opening.

protruding door furniture may reduce the usable opening.

Main door types are presented in Figs. 3.14.-3.20. Matters which must be considered relating to an opening a door include the type of door, the mechanism for opening the door whether manual or automatic, method of locking the door, the danger of walking into the door, the danger of a person being hit by the door being opened suddenly and the space needed by a person in a wheelchair on the lock side of the door to operate the door.

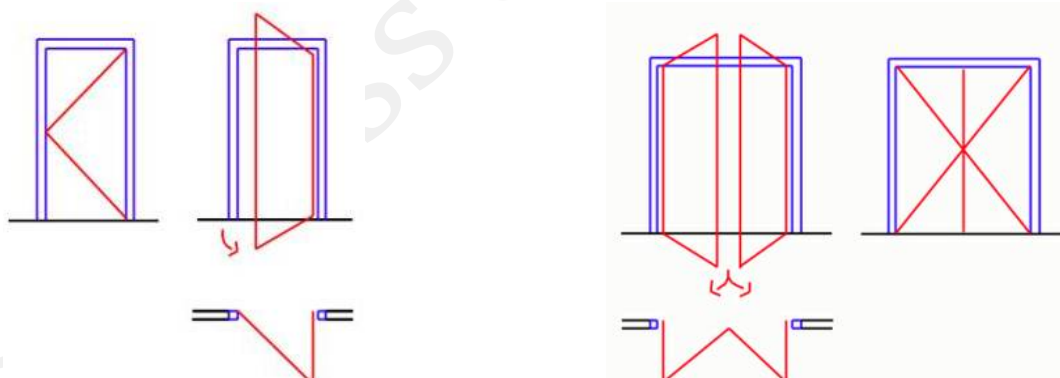

3.15. Single and double hinged door

The space requirement for opening and closing on both sides is illustrated with over copying the positions of a manual wheelchair in consecutive phases of operating hinged or pivot door.

No difficult manoeuvre is necessary if a kick-plate is applied which can be simply pushed with the footrest of the wheelchair. A suitably designed and positioned kick plate will, not only protect the door, but facilitate the wheelchair user.

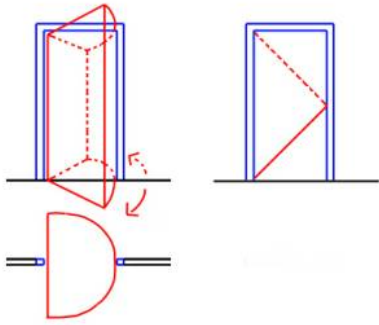

3.16. Kick plate facilitates the opening simply pushing it with the footrest

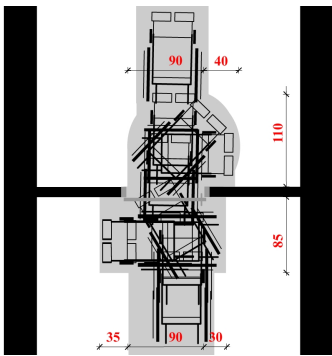

In addition to the size and location, the kick plate should be of aluminium or tough plastic to allow the sliding action of the footrest against it.

A hinged-pivot door is shown in Fig.3. 18. Its special feature is that the floor area swept by the door leaf (marked with green) is much less than in the case of a (3.15.) hinged door (marked with red). As a result the opening manoeuvres are easier.

3.17. The phases of passing a hinged door



3.18. Hinged pivot door (the photos are from an exhibition, thus the door is not built-in

Sliding door is advantageous because the opening and closing manoeuvres are simpler and less space is required, first of all the open door does not represent an obstacle. Certainly the moving of the door leaf should be easy.

On the other hand either a part of the wall must be free of furniture or the gap in a double wall raise the problem of cleaning. Due to the limited air tightness, sound and thermal insulation sliding door are applied in indoor environment.

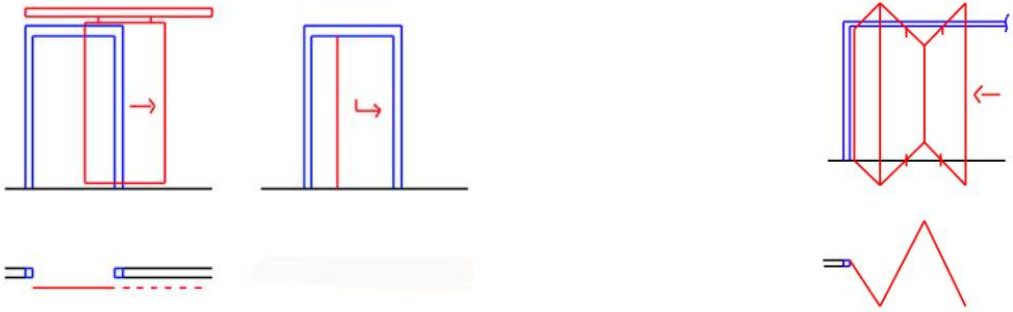

3.19. Sliding and folding door

Revolving doors are not normally considered suitable for people with impaired mobility or vision, people with guide dogs or people with young children or baby-buggies. Where a revolving door is provided this should be supplemented with a standard opening door which is available at all times.

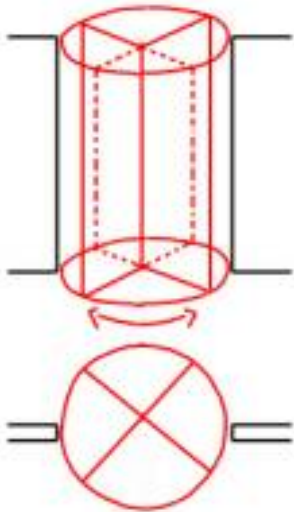

3.20. Revolving door

The method of opening a manually operated door will have a major bearing on how accessible it is to someone with a disability. Mechanisms which require operation by both hands should be avoided. Door opening mechanisms must be positioned at a height suitable for all users, whether standing or sitting in a wheelchair. Between 0.9m and 1.1m above floor level is recommended for lever handles, with 1.0m being the preferred height. It is recommended that pull handles should be positioned with their lower end 1.0m above floor level. These heights also suit children

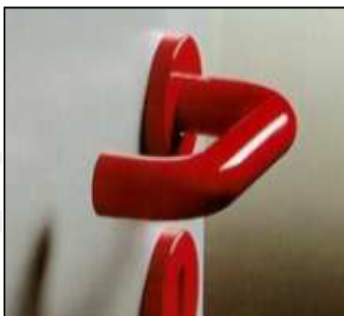

3.21. Correct form of handles

Door opening mechanisms must be suitable in their shape and force required for their operation for users with limited dexterity and strength. Spherical knobs which require a twisting motion are difficult or impossible to use by people with limited hand grip and by many elderly people. Lever handles shown in Fig. 3.21, facilitate those with impaired dexterity and can be operated using an elbow or the edge of the hand by those carrying objects.. The bend at the free end avoids

problems with clothing and bag straps catching on the handle.

Pull handles are recommended for installation of doors without latches and are suitable for those with impaired dexterity.

It is vital that the force required to open a manually operated door, especially heavy doors and those fitted with self-closing devices, should be as low as practicable and should not be greater than that which a person with a disability can exert: the required force should not exceed 25N. Other recommendation allows 30N for the first 30° of the opening cycle nor 22.5N for the remaining 60°. The use of hinges with low friction bearing will help to minimise the opening force required.

In extremely cold conditions, the shock caused by a person's hand coming in contact with a cold external door handle or lever could trigger an attack of Reynaud's disease or the skin can adhere to the fitting. To avoid this, such fittings should be made from or coated with materials which are warm to the touch (i.e. have low thermal conductivity) such as plastics or wood.

Self-closing devices are often fitted to doors for protection from the elements, security, privacy, noise control or fire safety reasons. Self-closing devices on single swing doors can be problematic for people with guide dogs, low upper body strength, walking aids or wheelchair users especially when additional resistance to opening is exerted by weather seals, wind pressure and/or faulty or inappropriate hinges. On the other hand, if the opening and closing force is not excessive, self-closing devices can be an advantage to a person with a disability by closing the door automatically.

Correctly installed power operated doors help people with disabilities to overcome barriers. Doors with powered operation can be activated automatically or manually and most types of doors (swinging, sliding, pivot or balanced) are suitable for powered operation.

Automatic activation, when correctly installed, should ensure that a person approaching a door does not have to hesitate whilst the door is opening. Automatically activated doors are normally arranged to close automatically after a delay under power or under the action of a door closer. The position and setting of any automatic activation device is critical to the effective functioning and safety of the door and in ensuring the intended flow of pedestrians is achieved.

Control mats, should be able to detect the presence of a wide range of pedestrian and associated traffic, e.g. walking sticks, trolley wheels.

Motion sensors comprise either radar or passive infrared sensors which are installed in the centre of the door frame above the door, or on the ceiling. Presence sensors are typically infrared, but may also be ultrasonic or capacitive types, and operate by detecting movement and objects within a detection area. Presence sensors are able

to detect stationary objects and people who are moving slowly, and are therefore suitable for use as safety as well as activation devices.

At entrance doors of a flat the callers should be identified for security purposes. Where a wide angle viewer (or spy-hole) is deemed necessary consideration should be given to fitting two, one at 1.4m above floor level to suit a standing person, the other at 1.0m to suit a person in a wheelchair or someone of short stature.

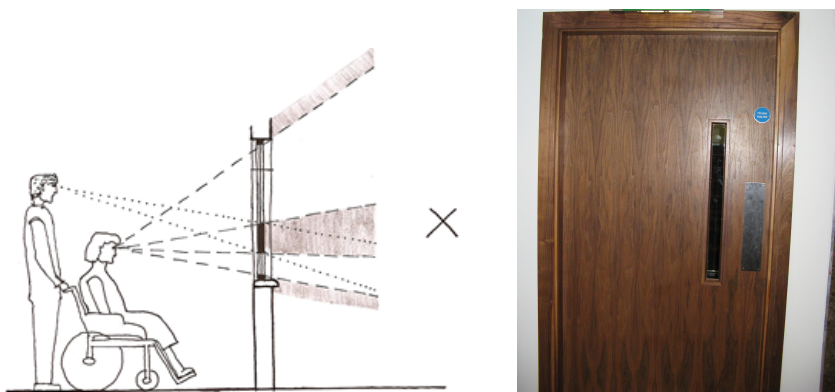

3.22. The callers should be identified through the entrance door



3.23. Protective strip

These heights are below the standing eye-level of 99% of the population and below the eye-level of 99% of wheelchair users respectively. Nevertheless it is a question whether the wheelchair user could bend to the spy hole. A vertical glazed panel is free of this problem. It may be crossed with a transom, depending on the size and material of the door leave.

Many details may serve the usability and comfort, not only for disabled and elderly people. One of these is the hinge closing protection.

On the hinge side of the door, protective strips will prevent users, particularly children, being caught between the door and the frame on the hinge side.

4. Ramps

4.1. Moving in wheelchair on ramps

The ramps are indispensable for wheelchair users, comfortable for average persons, however unless appropriate measures are taken represents some risk for visually impaired and blind people. The ramp is a *plane* passageway connecting two different levels. Ramps are indispensable for wheelchair users, but not only wheelchairs have wheels. Everyday tasks, such as to push a buggy, a trolley, a bike, towing a luggage need ramps, as well. Even if one actually have nothing on wheels, the ramps are more comfortable than stairs for walking on it, especially if somebody uses walking frame, cane, crutch (these people are the “ambulant disabled”). Nevertheless ramps are comfortable and safe only if some simple but important rules are met.

The width of the ramps. The necessary width of a ramp depends on the expected traffic on one hand and on its length, on the other hand. The first is easy to understand: the minimum width must be enough for a wheelchair. No less is the requirement, if you use crutch, walking frame, or you have luggage. More space is necessary if traffic from opposite direction is expected. What about the length? The longer the ramp, the higher the risk that somebody is coming from the opposite direction. Certainly, wider ramp is necessary in a park, at a railway station, at the entrance of a public building or a shopping centre, while the minimum can be accepted in a home.

There are indoor and outdoor ramps. As far as the size and geometry are concerned, the rules are the same. The difference is in the floor covering: outside the water diversion, the problem of frost and snow are important – there are more safety aspects. The necessary width of ramps is the same as that is on horizontal plane.

The slope of the ramps must not exceed 5%, thus 5 cm height difference for 1 m length, projected on horizontal plane. Exceptionally 8% may be accepted if the length is less, than 2,12 m. It means that the height difference must not exceed 17 cm.

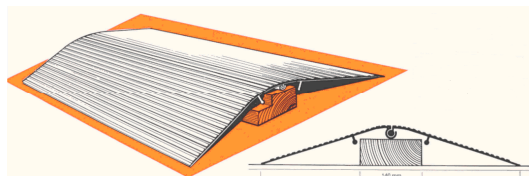

4.1. Threshold ramp

The height of thresholds should not exceed 1,5 – 2 cm. It is favourable to round its edges. In case of higher thresholds transportable ramp, shown in Fig. 3.24. can be the interim solution.

It is easy to understand, that considerable force is necessary to drive up a manual wheelchair on a steep ramp – and the wheelchair user may have powerless arms or hands. It should not be forgotten that driving down on a steep ramp is risky: the brake of a manual wheelchair is for to make fast the wheelchair, but not for slow down it.



4.2. The footrest may impinge the ramp

Less known is that the wheelchair cannot move on a steep ramp even if it is a short one. The footrest is typically in a height of 7 cm, it may impinge the ramp. This problem is frequently forgotten in the case of a short ramp, e.g. a curbed ramp on the street. The footrest may be at a higher position – but in this case the seat must be in a higher position – together with the centre of gravity! The gravity force, starting from the centre of gravity (one may estimate, it is somewhere in the stomach in case of manual wheelchair) must impinge the soil between the wheels, otherwise the wheelchair capsizes. Bending forward the gravity force vector may be kept between the wheels, so the risk of the balance may be avoided, however there are disabled people, whose seating is not stable. They must use safety belts and cannot apply this trick. Only a strong assistant may prevent the casualty, pushing and balancing at the same time the wheelchair – but even this is risky, if the surface is slippery, e.g. on an outdoor ramp.

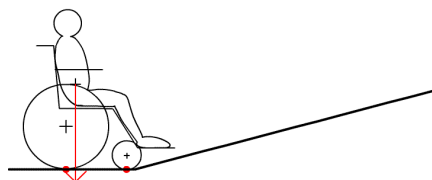

4.3. The balance can be kept only if the gravity force impinge the soil between the wheels.

A long and steep ramp is risky when driving downwards: the wheelchair may accelerate, its brake is for to make fast the wheelchair, but not for slow down it. The landing may become an accident. Exceptionally a very strong parapleg person could make use of handrails, but it cannot be expected in general and the manoeuvre is not without risk.

The length of the ramps. Driving up on a long ramp is exhausting, Downwards it may be risky: any device on wheels may accelerate, majority of them does not have brake or the brake is for making fast the device only. Therefore at every 50 cm height

difference – in other terms at every 10 m of length – a horizontal platform must be provided. The length of this horizontal place should be minimum 1,50 m. Supposing, that the wheelchair user change the mind and intend to go back, the width of this horizontal place must facilitate the turning: the diameter of a turning circle is 1,50 m for a manual and 1,70 m for an electric wheelchair: this is the necessary width. Would be the height difference great, it is not likely that we have enough place to provide a straight ramp in one direction. For example: if the height difference is 2 m, the length of the ramp should be $2 : 0,05 = 40$ m plus $3 \times 1,5$ m horizontal platform, in total 44,5 m ! In such a case the ramp should be built in zigzag. The direction can be changed at the horizontal platforms or in other terms, wherever the direction changes, or the geodetic height difference exceeds 50 cm a horizontal platform must be provided!

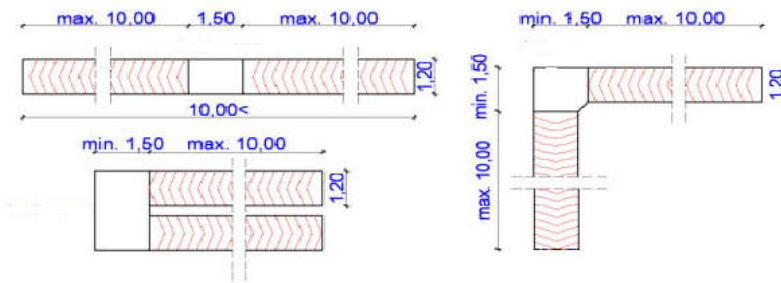

4.4. At every 50 cm height difference a horizontal platform must be provided, facilitating the turning of wheelchair and the change of direction

The ramps are space requiring: a massive ramp, with interim horizontal platforms is shown in Fig 4.5. (estimate the height difference, in comparison with the stairs). Fig. 16. shows an other example where the changing of direction is on horizontal platform and the space requirement of ramp and stairs can be compared, again.

The ramp as a passageway. Repeating the definition of the ramp: “the ramp is a **plane** passageway” thus it consists of planes, either horizontal or sloped. The wheelchair



4.4. Straight ramp



4.5. Zigzag ramp

user is moving along its axis, turning and change of direction are carried out on horizontal platforms. The definition is of high importance. The reason is quite simple. Most of the wheelchairs have four wheels. All must be in contact with the surface of the way, none of them shall be in the air, otherwise the manoeuvres or the keeping of the direction will be hampered. This is the case when the wheelchair user is forced to move slantwise at an angle to the axis of the ramp or on a curved ramp

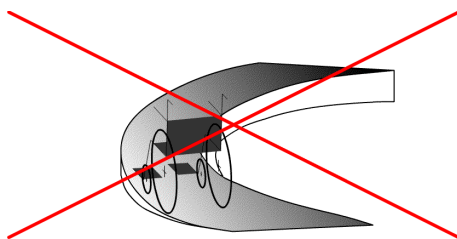

4.6. On curved ramp the wheelchair cannot be used

Outdoor ramps are exposed to rainfall therefore water diversion should be provided. Nevertheless the cross slope must not exceed 2 % otherwise the manoeuvrability of the wheelchair becomes critical. At the landing the water should be collected and disposed of.

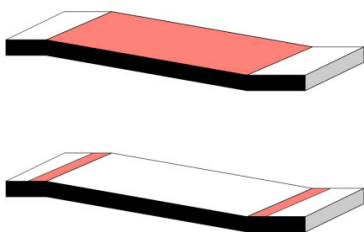

4.7. Ends of the ramp must be signed with colours and tactile information

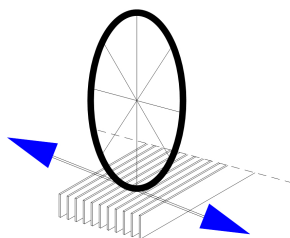

4.8. Grid elements over the sump should be at right angle to the moving direction

The distance must be less than the width of the wheel and the grating should be perpendicular to the direction of the driving

Due to snow or ice an outdoor ramp may become slippery wintertime. Even if it is provided with a canopy, driving rain or snow may fall onto it. The safest – no doubt, expensive – way to keep the ramp dry is its heating. Heating can be provided either with electric cables or with tubes (like floor heating), in both cases embedded in concrete. Possibly even temperature distribution on the surface is required, therefore the distance between the cables/tubes is limited and they should not be too close to the surface. Reinforcement or metallic mesh over them promote the lateral heat flow, thermal insulation below them decreases the heat losses towards the soil. In case of tubes their network should be connected to the heating

system of the building with a heat exchanger and the energy carrier must be antifreeze liquid.

In order to prevent accidents ramps must be provided on both sides with wheel guard.

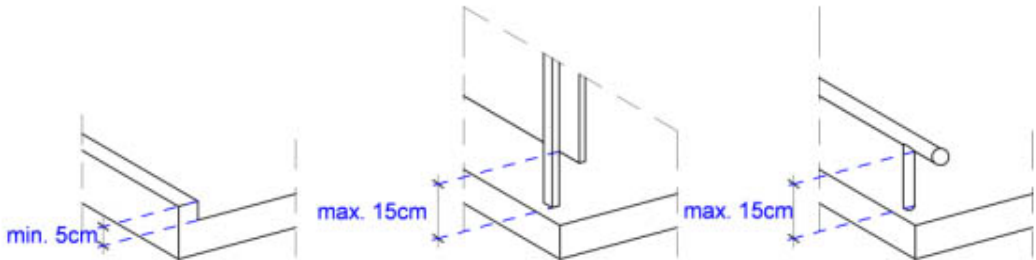

4.9. Wheel-guard

A correct ramp is shown in Fig. 4.10. As far as the handrail and the visual marking are concerned see chapter 8.

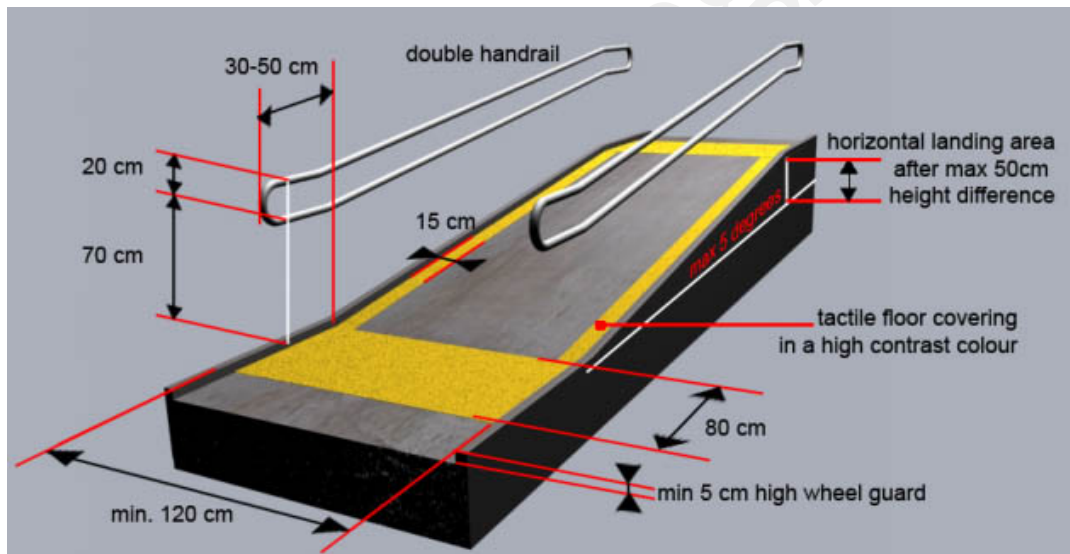

4.10. A perfect ramp

4.2. Handrails

The handrails are commonly used elements – special needs of disabled people require more attention to a few details. Grab bars are the safety devices meant for those having physical disabilities in the house. The handicapped persons use them to maintain balance, cart away and prevent falls. The common accident that happens among the disabled are the falls within the house when they try to do certain things

themselves, thus requiring less or no personal assistance. They mostly need these things in the bathroom and therefore they will be analysed in chapter 6.2.

The handrails along the stairs and ramps are obviously and commonly used elements. To fulfil the requirements of disabled people the following rules should be considered:

- a pair of rails are to be applied at the heights of 70 and 90 cm,
- the rail should be continuous, extending at both end of the stair or ramp with 30 – 60 cm, the change of the slope of the rail marks the ends of the stair or ramp.

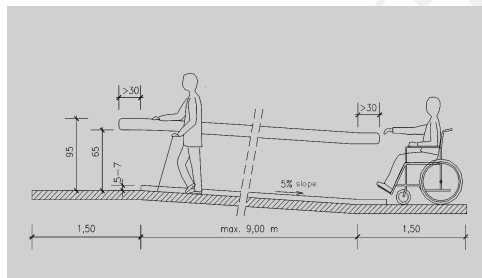
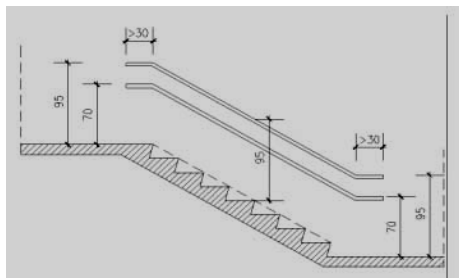

4.11. Handrails should be extended at both ends of stairs/ramps

The size and form of the rail should easily be gripped, the cross section should be circle or ellipsis. The brackets should not prevent the continuous grip of the rail.

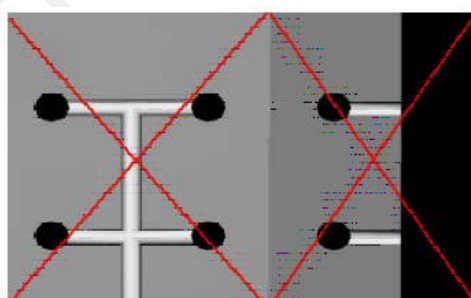
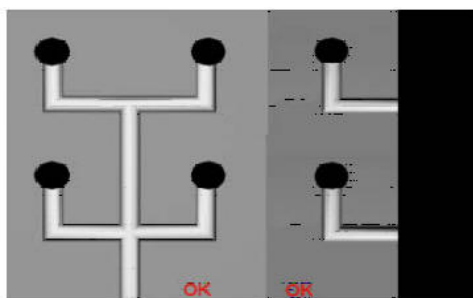

4.12. The brackets should not prevent the continuous grip of the rail.

Regarding the materials the followings are to be mentioned

- grab bars and handrails should be robust,
- they should not be slippery,
- first of all in public buildings the possibility of cleaning is of importance,
- some people has allergic problems if they touch metallic elements,
- especially in outdoor environments the heat effusivity of the material must be low in order to prevent the low contact temperature.

The recommended width of stairs is a minimum 1,20 m clear of protruding handrails. On both sides double handrails shall be provided, protruding the length of the stair by 30 cm. If the width exceeds 2,40 m, handrails shall be provided along the centre line, too, thus wherever you walk on the stair, the handrail must be available nearby.

5. Home

One of the most important places in life is the home. The needs of wheelchair users represent the most extreme requirements however according to the basic philosophy “what is indispensable for a disabled person is beneficial for the others”, an accessible apartment is more comfortable for everybody. In the followings the needs of wheelchair users are considered since they are the most demanding ones.

Not all flats should be built for wheelchair users however in any flat may somebody become wheelchair user and in more one there are or will be elderly people whose needs are similar. Many problem of the adaptation can be prevented complying with some basic rules of universal design. The most important rule are analysed separately: doors in chapter 3.2, bath and WC in chapter 6.

5.1. Spatial limit of manipulation from wheelchair

Typical geometric data and the spatial limits of manipulation are shown in Figs 5.1. and 5.2. All switches, plugs can and should be in a height where wheelchair user can reach.

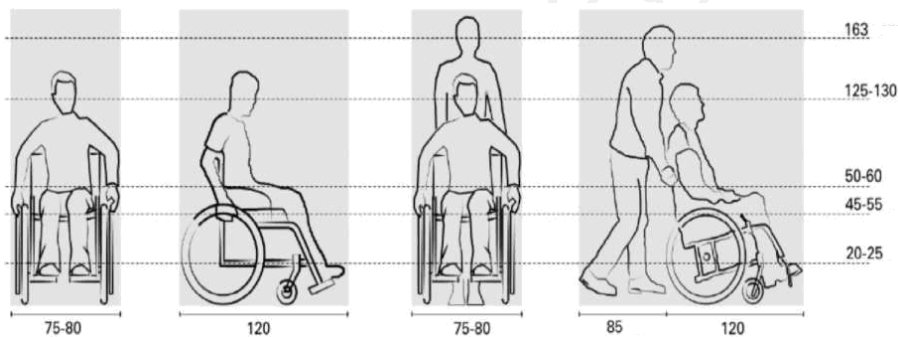

5.1. Anthropometric data of wheelchair users

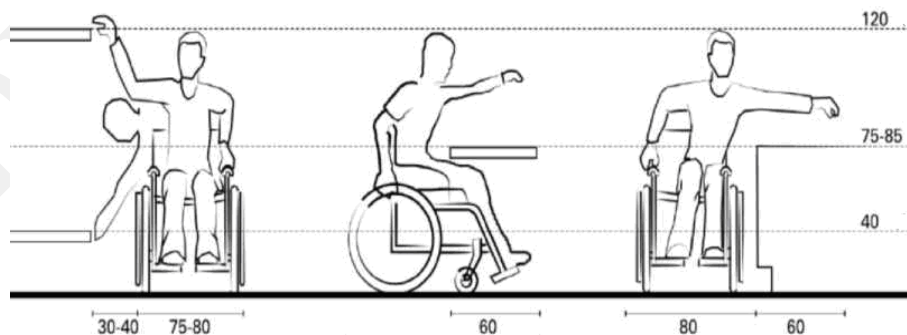

5.2. Spatial limits of manipulation

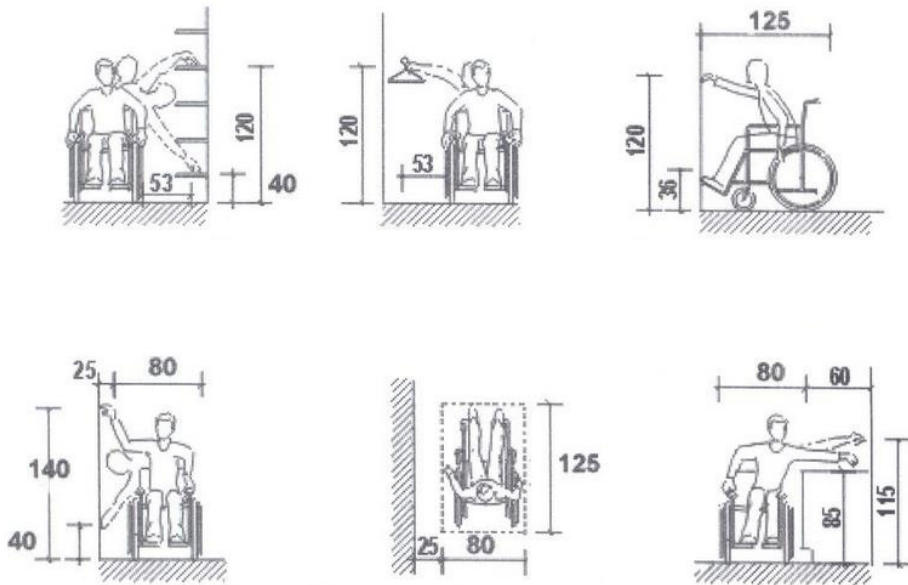

5.3. Space requirement of activities

Eye-level is important since we have to see what is at our hand and how we can grip something. It is useful to have transparent shelves above the counter or to install a mirror over them to be able to see the things on the shelves from below.

5.2. Entering the building

The main entrance and its surroundings must be designed for possible use from a wheelchair (drainage, door, door handle and penthouse). A block of flat has a common entrance area and lobby, the place of some activities, which are simple if the message of Figs. 5.2. and 5.3. are considered. The operator equipments should be installed at 80-110 cm, thus those are within reach from a wheelchair as well. The width of the free movement space must be at least 120 cm and there should be at least a 150 x150 cm free place in front of the elevator or apartment door. All signs of the entrance (street number, entry phone, etc.) must be lit to be well visible and noticeable.

It is to be mentioned that although the needs of habitants are focussed on the disabled visitor of a home should not be forgotten. Obviously no all activities should be made possible for visitors however the minimum is to facilitate the entering the flat which is to be solved at the entrance and in the common area of the building.

Details are analysed in chapter 3.2. (entrance gate and door), in chapter 7. (signage) and chapter 8. (visual and tactile information).



5.4. The door opener and the mailboxes should be installed at no more than 80-110 cm height.

5.3. Cupboard and shelves

The highest shelf should be at 130 -140 cm. The shelf over the eye level can be made of glass or plexi: being transparent one can see from below what is on the shelf.

Clothes can be hanged on a rack however if the rack is at reachable height no place remain below the clothes for other items. The solution is a collapsible rack sometimes called as „clothes-lift”.

The drawers of the cupboard should be easy to handle and be able to be pulled out fully.

Hinged doors require more space in front of the cupboard, thus using sliding doors is more advantageous. Recessed base of furniture or at least 30 cm high footing is recommended for better use of the space and for the foot-rest of the wheelchair.

The rail can be at 120 cm height or adjustable to different heights.

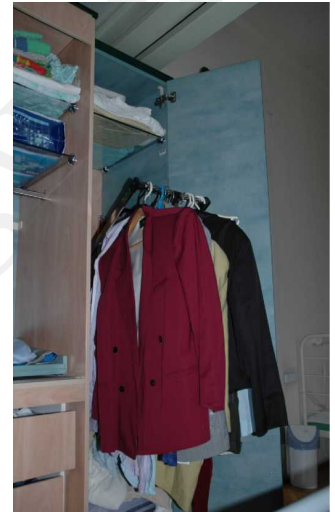
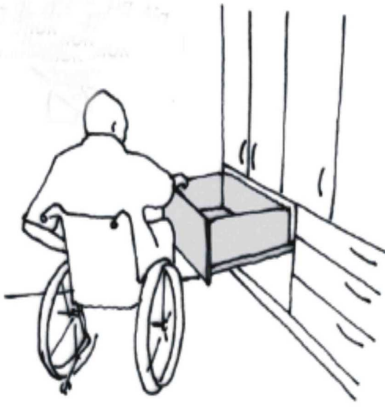

5.5. Transparent shelves and collapsible racks facilitate the easy use

The shelf above the rail should be transparent in order to be able to see from below what was put on it. It is always more advantageous to have a pull-out, rolling container or a rolling cupboard element.



5.6. Deep drawers and containers

5.4. Bed and seat

In case of a wheelchair user, the bed should be positioned to allow clear approach from at least one of sides. The best solution is if the bed is accessibly approachable from both sides. In case of seriously disabled persons, that require a personal assistant or special equipment to get into bed, the access from both sides is necessary. If a personal assistant is needed, a bed with adjustable height is the best solution. For getting into bed from a wheelchair, the height of the bed should be positioned at a height of 70 – 75 cm for dressing. For sleeping, a lower height is recommended.



5.7. Bed with flexible elements

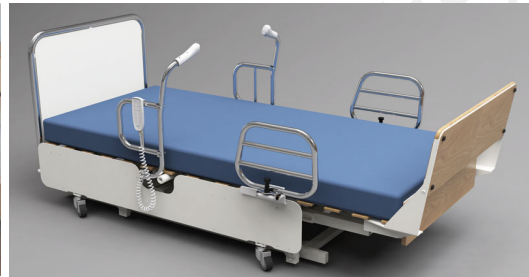

5.8. Grab bars on the bed

Lying down and getting up from bed is a basic procedure of our daily routine, right after waking up. However, persons with disabilities, and people with several forms of physical impairments or limitations have difficulties in performing everyday activities, such as transferring in and out of bed, (lying down, sitting up) or in simple moving or relocating position. Grab bars, bed assist rails or fixed handle placed on the unimpaired side of the patient provide solid support for transferring in and out of bed. It can also help to reduce the risk of injury caused by one-sided effort of reaching and twisting

For seriously disabled people with better hand motion, a bed with remote controlled, rising head- and foot ends is useful. It can be adjusted to their personal needs. Adjustable bed gives great help. Height adjustment and raising the upper body assists users in getting out of bed with little or no assistance, dependent on their condition. To operate the bed, the personal assistant should push a handle, or it can be motorized and be activated by pushing a button or by sound as well.

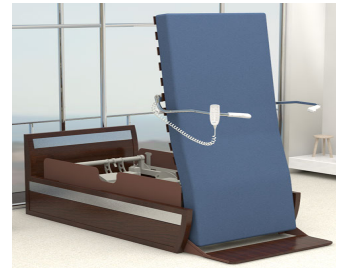
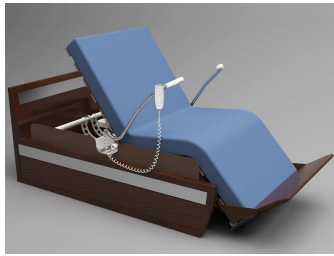

5.9. High-tech bed can be used for sitting and helps standing position

Due to paralysis or loss of function of all four limbs normal functions and strength of the limbs cannot be counted on. Therefore special handicap products are needed to assist with all complex operations.

High-tech solution facilitates the laying, sitting positions as well as the standing up. To spend some time in vertical position day by day is important for disabled people from the point of view of maintaining healthy blood circulation. The grab bars can be supplemented with belt if necessary.

An emergency call bell should be provided by their bedside. This should be activated even with a simple spat (hit) as well. Smart home system provides full-scale accessibility, convenience and availability for everyone. These systems make normal activities of daily living possible for the elderly and disabled.



5.10. Desk which can be used in bed

Rolling or sliding tables facilitate some activities (eating, reading, writing, needlework) in the bed.

Regarding chairs, armchairs it is useful to have the same sitting height as it is in the wheelchair. Special medical design - where the sitting height, the backrest (remote controlled), the footrest, the neck rest and the cushioned armrest are adjustable - provides comfortable standard for everybody. Tilting the chair makes easier standing up.

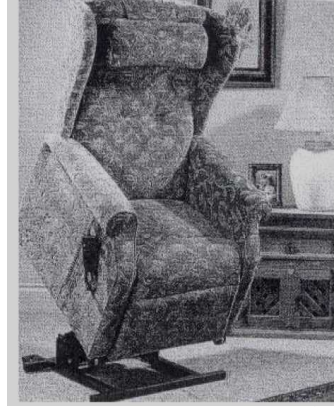

5.11. Tilting the chair makes easier standing up



5.12. Foot-rest and tilting the chair

5.5. Kitchen

Part of the housework comes to life in the kitchen, where food is made from different raw-materials. It is important that this task could be done leisurely, quickly, safely and with the least effort. For this reason, transparency of the kitchen is a basic principle. The kitchen should not be over-packed with furniture or other things because those can keep from free motion and transparency.

Practical inner design of furniture provides space to install the different home appliances. Shelves and containers on the wall may contribute to comfortable work in the kitchen, providing the spatial limits are considered.

Upper cupboards can be used easily applying cupboard -fittings which can be turned out or lifted up and down adjusted to the level of work-counter. The special fitting/hinge is operated with electricity.

These solutions are comfortable for standing and for sitting persons, as well – in many kitchen different persons may work in the same environment. Similar is the case of worktop with adjustable height.



5.13. The upper cupboard gains distance from the wall when moving down (left). Only the shelves lower, the cupboard itself remains (right).



5.14. Foot-and knee-free furniture is basic requirement

Figs. 5.14. illustrate the importance of foot-free and knee-free furniture. Even if a “normal” kitchen is spoken of it is important to provide the feet-free space – in case of any unexpected necessity the adaptation of the flat for a wheelchair user is much more simple and cheap if the floor covering and furniture should not be rebuilt.

Under at least one of the counters a knee-free space should be left with a 120 cm length without containers.

The remaining containers can be more easily used if hinged or revolving shelves are applied.



5.15. Knee free counter is to be provided to facilitate the manipulation on the worktop



5.16. Revolving shelves

The layout of the kitchen can be evaluated from the aspect of necessary floor area and the necessary manoeuvres of the wheel-chair user.

One-line arrangement is not favourable, because relatively big distances should be covered many times between the different functions. Width of the kitchen should be at least 180

cm. From this, the depth of furniture can be 60 cm, leaving 120 cm clear unobstructed space if long enough knee-free counter facilitates the turning. Length of the kitchen is minimum 360 cm in order to allow enough surfaces.

In case of a two-line arrangement, considering the depth of furniture minimum 2x40 cm or 2x60 cm and the minimum 120 cm distance between the two lines, the recommended width of the kitchen should be at least 240 cm. The recommended distance between the counters is 170 cm.

The L-shape arrangement is as beneficial as the U-shape. The width should be at least 220 cm and the length should be 240 cm due to the need for a longer counter.

The design of windows as they relate to people with disabilities will be considered under

It should also be recognised that fittings in front of windows (such as kitchen units, sanitary fillings or radiators) further restrict the reach of wheelchair users. In such cases, and for windows at high level, remote operation (e.g. pull cords) and power operation with remote activation should be considered. Windows with powered operation for opening and closing, if suitably designed and installed, help to overcome problems which may be experienced by those with disabilities.

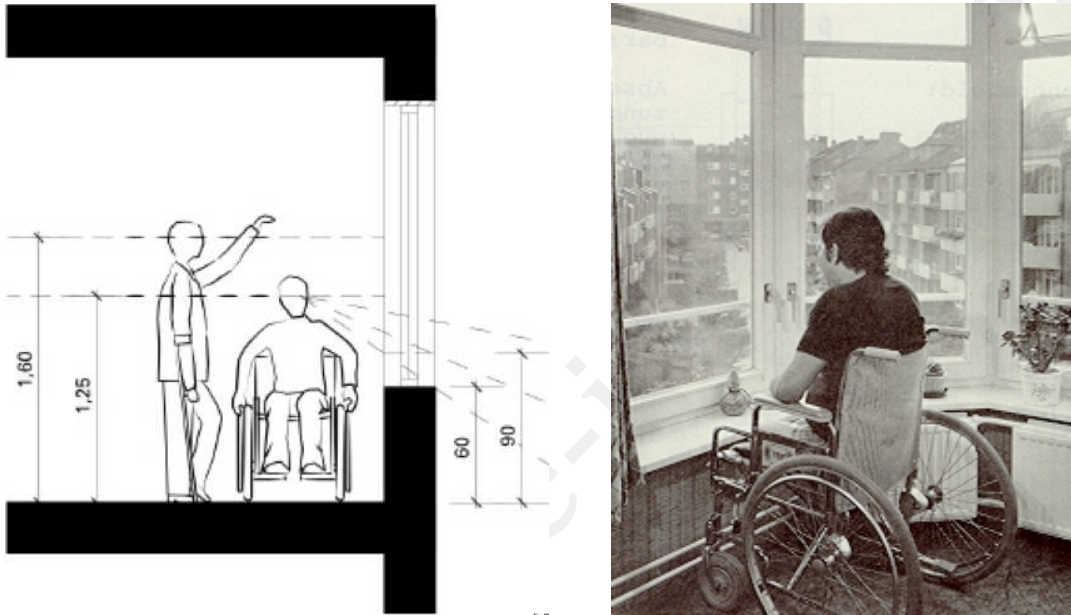

5.18. Window of a home designed for wheelchair users

Window opening mechanisms must be located in a position suitable for all users, whether standing or sitting in a wheelchair – the recommended height is 1.2m above floor level.

6. Bath and WC

A basic question of the independent life is whether the disabled person can take care of his/her personal hygiene. Few problems may result in such a feeling of helplessness and impotence as to be unable to use alone the WC, to have a shower. Certainly there are very serious impairments when the help of a personal assistant is inevitable, nevertheless the majority of impaired people is able to use individually the WC and the bathroom, providing their special needs have been taken into account whilst designing these premises and adapting correct installation.

The main problem of the usability is the space requirement. Providing the help of a personal assistant is inevitable much more space and special installation become necessary.

Besides of the common equipment of a bathroom several accessories and small details must be considered in order to enhance the comfort and the security of the user.

It is a fundamental question whether the WC and bathroom should be adjusted to the known abilities of a given person, or is intended for public use – in the last case all kinds of disabilities must be considered up to the limit of rational possibilities.

6.1. WC, bidet

Let us start with the most bulky piece, which is the WC itself. It can be standing or wall mounted. Both versions are satisfactory, both have pros and contras. The standing one can be ulterior from the wall – in the case of a wall mounted one a special extension element is to be applied and due to the increased distance the momentum-balancing forces will be higher. On the other hand below the wall mounted one there is enough space for the footrest of a wheel-chair, less space is necessary for a turn, the floor area may be decreased.

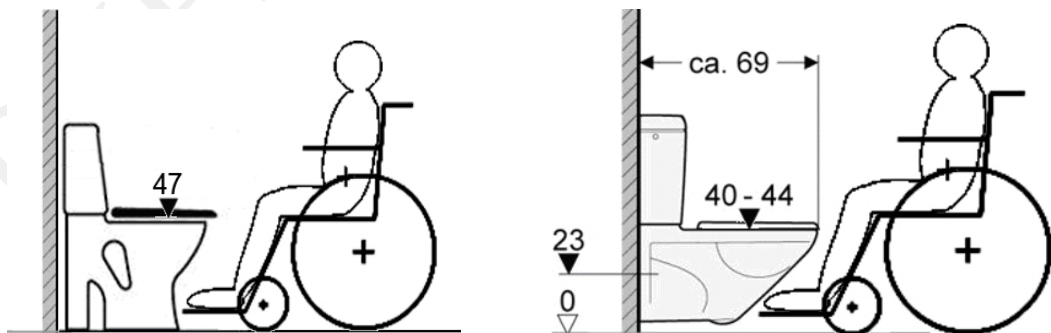

6.1. Foot free WC saves some floor area

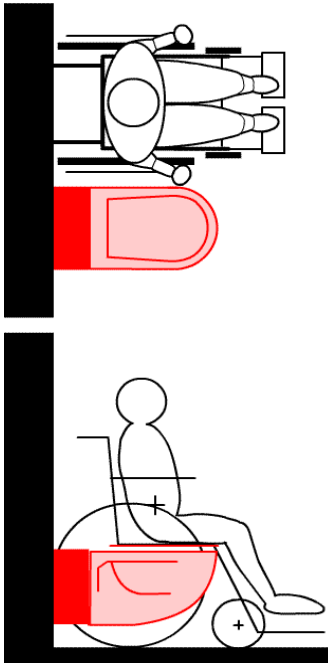

6.2. Extension element

The distance between the back wall and the WC must be more than usual in order to facilitate the slipping through from the wheelchair, standing at the side of the WC. Even if the wheels are in contact with the wall, the seat of it is about 40 cm from the wall.

Wall mounted WC should be completed with an extension element (marked with red in Fig. 6.2.). The distance between the standing WC and the wall facilitate the diagonal or parallel approach from wheelchair, the space is enough for a personal assistant, if necessary.

Many wheelchair users can only to slip through from the wheelchair to the WC and back, therefore it is important that both should be at the same height. The height of the typical wheelchair is more than that of a normal WC. The problem can be solved in different ways: using stilting element which can be put for a wheelchair user and can be demounted for others.

There are stilting elements of different sizes on the market, so the adaptation to different needs (including average people, too, and not forgetting the children) is fast and easy

Wall mounted WC can be put easily higher: it is stable and comfortable for wheelchair users and advisable in an accessible toilet, but may be uncomfortable for average people and risky for small children.

Not cheap but flexible solution: the WC can be moved up and down, even if somebody is sitting on it. So the height may be adjusted to the need of anybody, and lifting up may be a help to stand up for those who use crutch or walking frame. To improve the hygienic conditions and to save place (space requirements are crucial in an accessible toilet) the WC may be arranged so as it can be used as bidet as well, providing a flexible tube with a small shower head is available in a short distance. It can be introduced through the opening cut in the front side of the WC.

Obviously, the “double-purpose” version works only if there is a shower nearby, easy to achieve and control whilst sitting on the WC.



6.3. Stilting element



6.4. Variable height WC makes easier to stand up



6.5. The opening of the WC and the flexible shower nearby

This is a simple solution, favourable for those, whose manual abilities are limited, as well as for women and in some cases from ritual aspects.

The toilet and bidet function can be combined in a high-tech unit, which provides shower and drying warm air, controllable by the user. The movable elements (shower and nozzle) are washed automatically after each use. The drying air jet is exhausted along the perimeter preventing smell propagation.



6.6. High-tech combination of WC and bidet

The approach of the WC, the change from wheelchair to WC and back is a difficult manoeuvre. Different techniques are used depending on the ability of the person: slipping through. frontal and diagonal approach (Fig. 6.7.). Each technique requires grab bars.

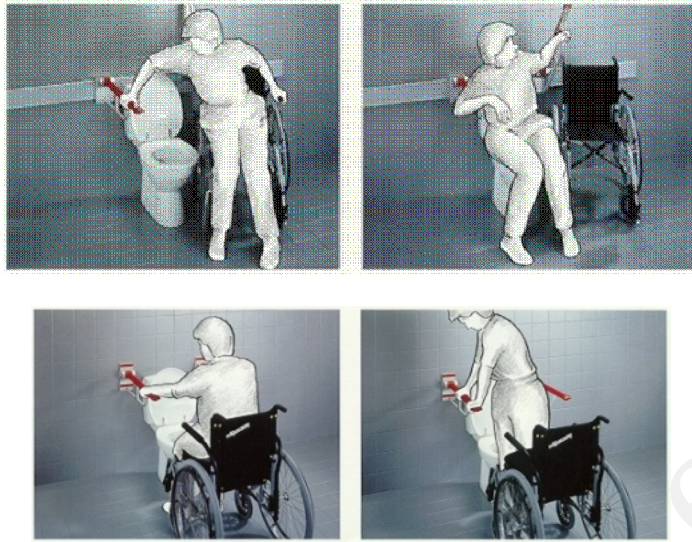

6.7. Techniques of changing the seat

6.2. Grab bars

Grab bars should be installed on both sides of the WC at 70-80 cm height from floor level: they can support transfer to the toilet from a wheelchair or persons with balancing problems.



6.8. Foldable grab bars



6.9. Wall mounted grab bar

In Fig. 6.8. the grab bars are folding ones on both sides – the toilet can be approached from both sides and there is place for personal assistant if help is necessary. On one side fix grab bar can be mounted on the wall (Fig. 6.9.): it is usually more stable, on the other hand the toilet can be approached only from one side and there is no adequate place for an eventual personal assistant. The typical forms, positions and sides are shown in Fig. 6.10. They have to facilitate both horizontal and vertical movement of the user - besides of the position not only their length but their height

is important, too. Imagine, how would you use your hands whilst standing on: the angle between your lower arm and the bar should be near to right one.

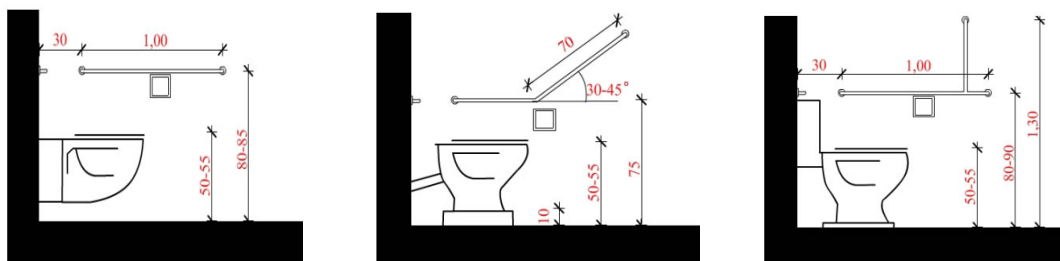

6.10. The appropriate size and position of wall mounted grab bars

The installation can be completed with a back-rest for those whose seating is not stable.



6.11. Back rest helps the stable sitting position



6.12. Ergonomic form of grab bar

The folding grab bars facilitate the approach of the toilet, at the same time it should be massive: imagine a person with all of 100 kg of body weight at the end of the bar – since hi/she cannot use his/her legs...This is why the folding ramp must be mounted in a reliably way on a stable wall. It should not be forgotten that while in use they are exposed not only to vertical but horizontal forces, too, and due to their length great momentum should be counterbalanced by a few screws.

Besides of the strength of the bar and screws in physical terms the psychological aspects must not be forgotten: imagine the feeling of risk if the bar is moving when you lean on since the bars alone are supporting your weight.

The bars must be easy to grip – the tricky turning (Fig. 6.12.) facilitates the use of either upper or lower bar. The position of the arm proves that the bar is exposed to both vertical and horizontal forces.

In most of the illustrations you can see that toilet paper is be placed so it would be able to reach while sitting on the toilet (a good solution can be installing it on the

grab bar or on a side wall at 90 cm from floor level). The concept is simple: usability with the minimum of movement and effort.



6.13. Hanging handles can be rotated around its vertical axis and pulled on the horizontal rail.

Hanging handles represent a very useful accessory. The handle can be gripped at different height and turn around its vertical axis

6.3. Washbasin

With regard to the washbasin the first condition of accessibility from a wheelchair is that space is to be provided for the knees. There is a big choice of fittings. Either tap or valve type is selected the problems of disabled hands must not be forgotten: the fitting should be operable by one hand, without grip, simply pushing it with wrist or lower arm, with minimal force. Automatic taps with infra sensors are good solution in public premises, on the other hand those with spring should not be applied.

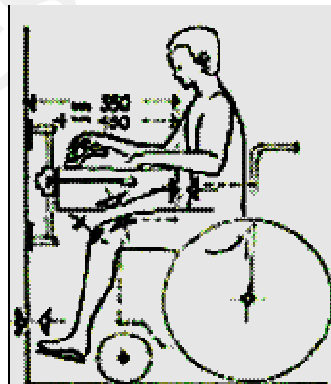

6.14. Knee-free washbasin

Automatic control with an anti-scalding system decreases the risk, resulting from the eventually slow and poorly coordinated unsure movement of the hands.

Under the sink the hot and cold tubes may result burns or freezing, and hitting these parts can also cause some injuries especially for wheelchair users (the nerves may be disabled, the temperature may be not felt, the risk may be not percept!) – covering them with a soft and isolating material prevents accidents.



6.15. Variable height wash basin



6.16. Flexible height wash basin

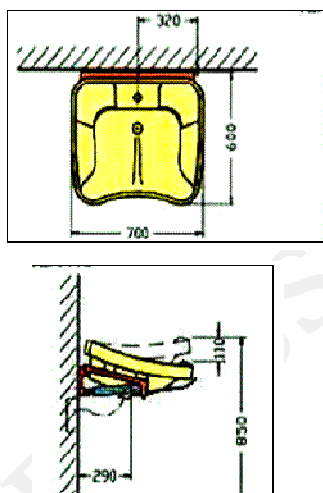

6.17. The tilt of the washbasin can be changed



Comfort of use depends on the position of the user: different height is comfortable for standing and sitting people (not mentioning the tail of the body. Flexible connecting tubes facilitate the application of movable sink.

A good solution is to install a tilting sink – so it will be accessible for different wheelchair models, children, and it also helps to be cleaned. The tilt of the sink can be changed using the frame below it.

Another feature, enhancing the comfort of use is the concave rounded front edge. These features are especially favourable when you wish to wash your face or hair: less effort is necessary to bend forward.

6.4. Shower, bath-tube

A wheelchair user can have a shower sitting. It is advisable to install a wall mounted perforated folding seat. Grab bars have to be installed preferably on each walls, one horizontal at 80-90 cm height, and a vertical one 0 -1,80 m height, so there is a good grip for sitting down, standing up or in case of falling getting up from the floor. All installed elements should be at 0,9-1,1 m height from floor level, available from the shower seat. The shower head should have a flexible tube, (fixed shower head is not suitable for use in a sitting position). The height of the shower head should be adjusted from 1,00 -2,00 m from floor level, adjustable in height and direction, so it will suit persons using them both in sitting or in standing position. The shower tap should be a one hand operable one, mixer tap is suggested, with a scalding-safe system (that prevents setting the water temperature over 40 °C unintended). Around the shower place a curtain is to be installed. It can be at a lower height if the shower is used only in sitting – in the last case it is easier to use it.



6.18. Accessible shower



6.19. The slope of the floor

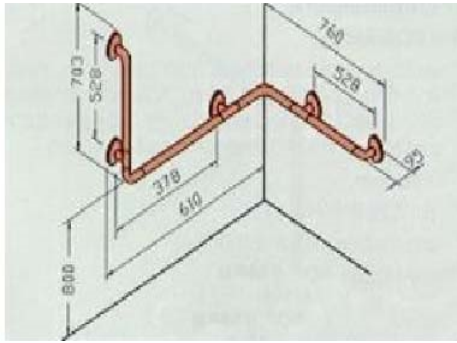

6.20. The correct sizing and position of the grab bars.



6.21. Example of shower in an accessible suite in a hotel

The simplicity of the shower place is illusory: the deepest point of the bathroom must be within the contour of the shower place (Fig. 6.19.) Let us start to calculate! The door of the bathroom should not have threshold (or 1 – 2 cm can be tolerated), thus the floor level is practically the same as in the neighbouring rooms. The slope of the bathroom floor should be 1% as a minimum - on 2 m it is 2 cm. The area of the shower place is 1,20 m X 1,20 m (in the photo marked with darker tiles). Within this the slope of the floor towards the deeper point should be 5% (or even more that of the tiles, forming the perimeter) - on one meter it is 5 cm. Thus the deepest point is below the normal floor level by $5+2=7$ cm! and from there must be the siphon connected under the floor to the sewage network with a tube of 50 mm diameter and 1 – 2 % slope, not crossing loadbearing elements or layers of the floor slab.

The use of bath tube can be made easier providing wall mounted grab bars.

The bathtub may be too deep for a disabled person - then various assistive devices may be used (simple, rotating or lifting seats).

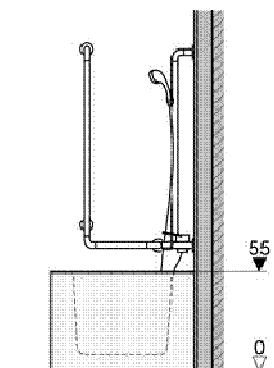
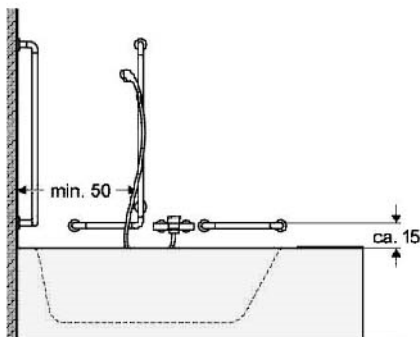

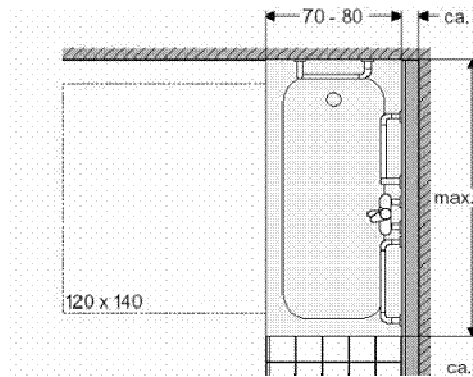

6.22. Bath tube with correctly sized and positioned grab bars

6.5. Accessories

Besides of the basic installation several accessories should be carefully selected and applied. The placement of the toilet paper has already been mentioned and shown. The mirror should be mounted above the sink that shows the whole body from both sitting and standing position – thus either a tilted one is necessary or a high one (in this case the lower part will be disturbed by other accessories and exposed to splashing water). The hangers should be placed at a height available from wheelchair.

All other accessories (soap automat, towel, ...) should be mounted at the accessible reaching level. Unique and non custom-like devices can be easy to operate if colours or visibility dots markings are used



6.23. Tilted mirror

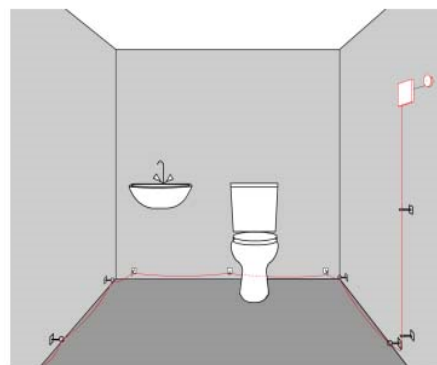

6.24. Emergency call with cord

Safety and security measures should not be forgotten. No door should be opened inwards the toilet or the bathroom – if somebody falls onto the floor, you cannot enter! Possibility of emergency call must be provided so that lying on the floor anywhere in any position it can be activated with the minimum of movement. One or

more button is not a reliable solution: a cord along the perimeter of the room at a height of 20 – 30 cm can easily be reached from anywhere.

6.6. General arrangement

The usability of a toilet or a bathroom mostly depends on the accessibility of the installation, thus enough space must be provided for the wheelchair manoeuvres and the slipping through.

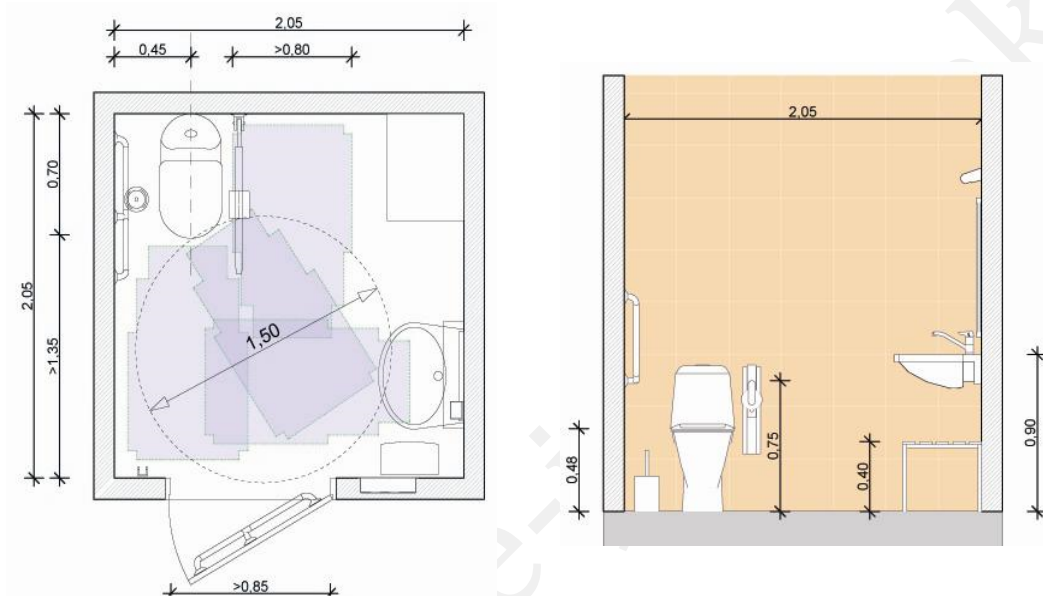

6.25. Accessible WC for a public building

Regarding the installation different combinations are possible: WC with washbasin, those and shower or bathtub, all together. Even the arrangement of the minimal

version: WC + washbasin represent problems which can be solved only with compromises.

The sink does not meet the requirement mentioned before but in this way of use neither the concave curved front edge nor the possibility of tilting are of prevailing importance because the use of the sink will likely be connected to the use of the WC only

In the case of public facilities you do not know in advance who will be the users and from which side of slipping through they prefer: free space on both sides of WC is the good solution. Designing for a given person whose preference is known it is enough to provide space on one side only. On the other hand it is believed that the washbasin should be near to the WC so that it can be used from sitting position. No doubt, such a way less wheelchair manoeuvres are necessary but the WC may be blocked from one side – moreover, if the washbasin is oversized, the WC front is blocked, too, and you cannot reach the tap. In a public toilet you wish to wash your hands – likely no need of an oversized basin. In this layout the sink can be reached from sitting position. A shower head can be connected with a flexible tube to the tap of it facilitating the bidet-like use of the WC.

The bathroom of a flat can be custom-made adjusted to the need and ability of the user – providing it is known who the user will be. When the user is not known, an arrangement is to be considered which facilitate the use for the majority of wheelchair users. This is the case e.g. in a block of flats or in the accessible suites of a hotel. Here WC, washbasin and shower are to be provided. Additional place may be necessary for washing machine unless it is not in an other room of the flat.

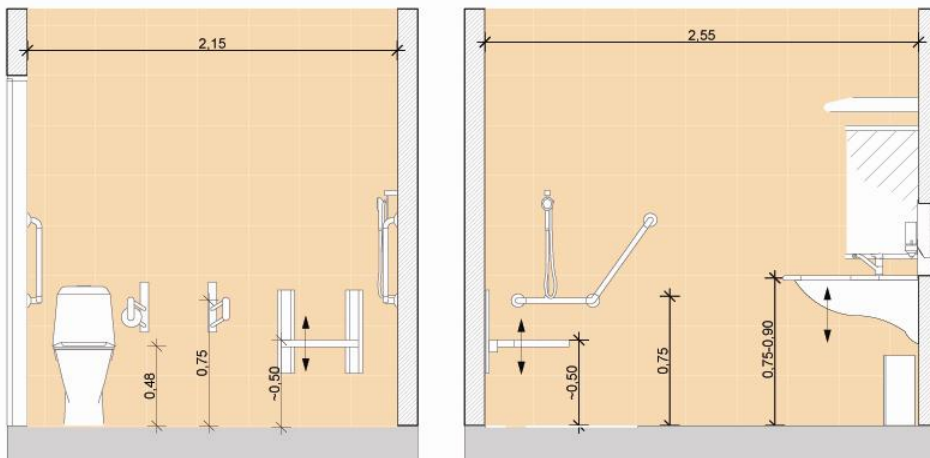

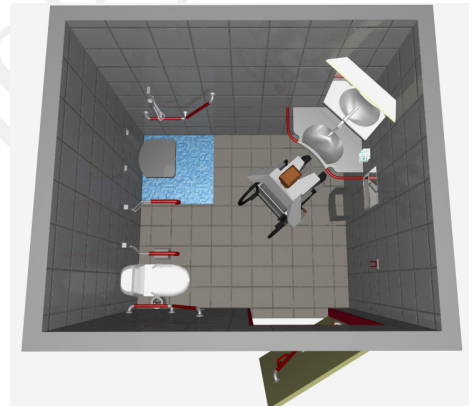
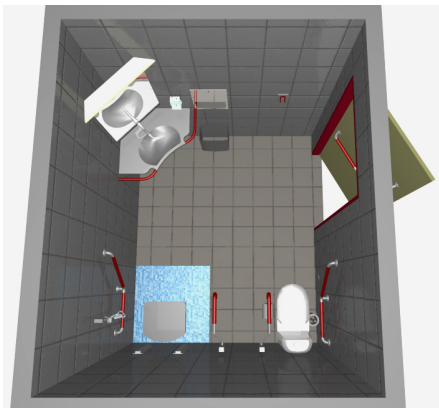
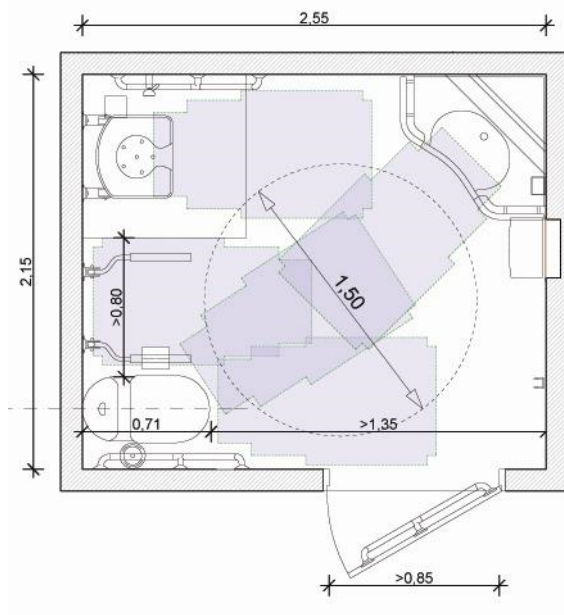

6.26. Accessible bathroom for a home

7. Public and commercial buildings

The accessibility and the usability of the public facilities by people of different abilities are of a crucial importance in the development of their self-independence. These two features are also a key tool for the achievement of a better quality of life.

Still nowadays, many public services such as banks, post offices and libraries, etc. are housed in existing buildings presenting architectural barriers in terms of: absence of suitable parking for disabled people; external inaccessibility (inadequate entrance doors, difference of levels, absence of handrails, etc.); internal inaccessibility (inadequate horizontal and vertical ways, guide dogs not admitted, lack of devices for people with sensory problems, etc.); absence of accessible bathrooms and toilets for disabled; impossibility to get to the manager's office, etc.

If on one hand the current regulation on the matter of accessibility states that every new project of such spaces must have an adequate level of accessibility, on the other hand a problem of adaptation of pre-existing, inaccessible and unusable buildings still persists.

It is important to emphasise that in such public spaces the question doesn't simply lay in the building of parking for disabled or in avoiding difference of levels. It isn't even a matter of guaranteeing more adequate spaces for the sake of wheelchair users, their mobility, steering, etc. It is also important to assure a comfortable and safe usability of the public service provided in the building. This can be achieved through the accomplishment of solutions that take into consideration the different types of disability.

7.1. Entering the building

The guarantee to reach the building can be assured through the implementation of:

Reserved parking for people with disabilities:

- the same level and very near to the entrance of the building. A flat path should lead the customer / employee from the parking to the entrance without him/her to meet any element that might resemble any to architectural barriers (flower pots or other static steady elements, small chains or other removable obstacles, sharp slopes). He/she might also be led through a path whose difference of level might be crossed with ramps in compliance with all standards ;
- in the underground of the building with access to the structure through elevators, platforms or other aids, ramp.

The marked parking place should be as close to the entrance as possible. The entrance door should have an accessible approach.



7.1. Entrances of commercial and public buildings

Nowadays, it is common characteristic of most workplaces to have a reception and the entry is possible with an entrance card. These conditions are valid not only for the employees, but for the visitors as well. In case of entrance cards, the reader of the opening system should be installed in a height that is viewed from a wheelchair. As for entrance systems, there should be other solutions implemented for wheelchair users.

The receptionist or the necessary information should be located in such manner that they could be clearly viewed from a wheelchair.

The automatic gate should be wide enough for an electric wheelchair otherwise a separate route must be provided – the last can be operated by the receptionist.

The reception can be located in a closed or open chamber. In both cases, the height of the desk (max. 100 cm) should be designed to allow free communication for wheelchair users too. There should be a shelf installed on the side of the counter at

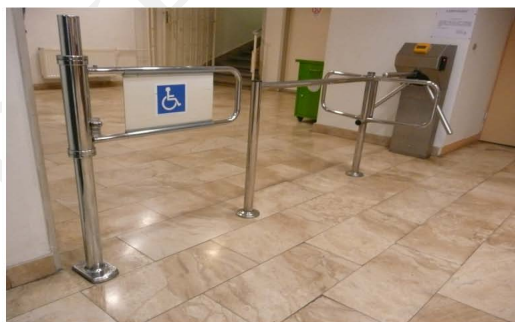

7.2. Accessible entrance must be provided

75 cm, where people can put their bags or papers. In case of a closed reception room, the shelf should be continuous on the whole length of the wall.

The counter should be knee-free on a min. 150 cm long section.



7.3. Accessible reception desks

In the lobby area information are to be provided in visual and tactile form. (Tactile information are dealt with in chapter 8.). The International Symbol of Access is used to identify accessible features and facilities used by persons with disabilities. Symbols of access are standardized and must be designed and used according to certain rules. The symbols of access are displayed.

Letters and numbers on signs should be in sans serif font and uppercase and not italic, oblique, script, highly decorative, or of other unusual forms. Arabic numbers are to be used. Letters and numbers on signs should have a width-to-height ratio between 3:5 and 1:1. Another way is to find fonts where the width of the uppercase letter "O" is 55 percent minimum and 110 percent maximum of the height of the uppercase letter "I". Very thin or thick characters are difficult to read.

Pictograms can be accompanied by the equivalent verbal description placed directly below the pictogram.

In public buildings fire evacuation rules, emergency exit signs must be displayed.

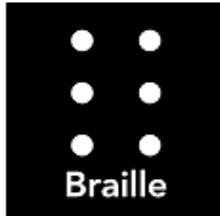

7.4. The most important symbols of accessibility

The form of the symbols of access complies with the following:

- consists of two elements, namely, a symbolised figure and a plain square background
- on the left see examples of the proportional layout of the symbols,
- the colour of the symbolised figure is white on a blue background or white on a black background (also black on white background).

Characters or Braille are not located in the pictogram field but directly below the pictogram field.

All text has to be:

- in title case,
- arranged with left alignment.

Arrows are located on the side of the sign to which they are pointing, that is, arrows pointing left are on the left and arrows pointing right are on the right.

7.2. Moving in the building

After the entrance, accessible horizontal and vertical movement should be provided inside the building. Corridors in each floor and larger areas connect the entrance and the different rooms. General principles of accessibility should be applied here as well: clean, not slippery, continuous surface without level differences (or appropriate solutions).

The use of the services provided within the building can be guaranteed:

- if among the personnel someone has been trained in the field of attendance of people with different abilities;
- if totally or partially lowered desks have been set up, so that users on wheelchair can be attended in post offices, in banks, receptions, etc. This is to avoid a person on wheelchair having to meet an inaccessible desk after he/she has parked, got into the environment and reached the area where the service is provided;



7.5. The corridor must be free of built-in and other obstacles

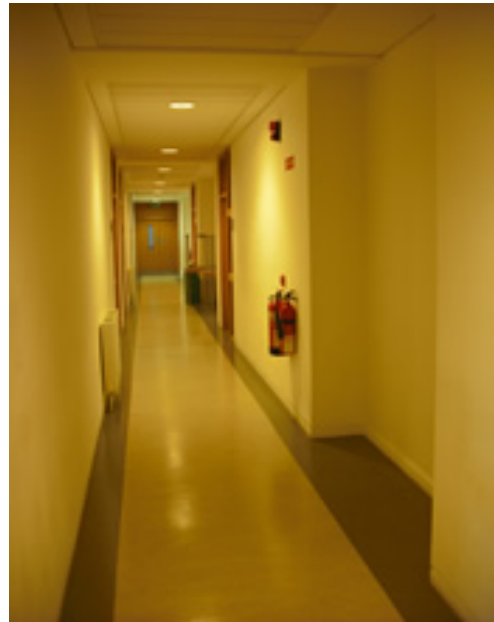

7.6. In a narrow corridor bays facilitate meeting or U turn of wheelchairs



7.7. Doors – especially when suddenly opened – disturb the traffic along the corridor. Bays at doors eliminate this problem.



- if the required space for wheelchair steering is assured, particularly in the area before the reception desk, in front of the banks and offices counters;

- if carpets and moquette are absent, particularly in the area before the reception desk and in front of the banks and offices counters;
- if the emergency exit is available and easily distinguishable in the reception areas and in the common spaces;
- if at least one hygienic facility is available in the common areas (reception, etc.). It has to meet all standards of adaptation for disabled people and is easily distinguishable thanks to a proper signage system including also Braille writings.

7.3. Employees

In many European countries it is compulsorily required by law to employ disabled people and protected categories. These buildings must, then, be accessible to employees of different abilities and not only to customers.

Only the capabilities of the person might limit the employment of disabled people. Providing accessible environment, they are capable of working in different positions in different fields. We can say that they can be employed in every field of economy in jobs (either physical or intellectual) that are appropriate for their condition and capabilities. Thus besides of clients many public building should be accessible for employees. Disabled employees may arrive or leave “on foot”, thus in wheelchair – in this case they need a changing room. Accessible changing rooms can be cubicle-type. Facilities should include a bench, rack or hook at max 110 cm height, free space for turning around in a wheelchair, mirror (for full body). The height and design of the lockers should be corresponding to the reachable height of disabled persons. It is advantageous to directly connect the changing room for disabled persons with the shower and toilet.

Accessibility of a workplace is provided also by designing at least one shower for disabled persons by changing room and by sex. Accessible pathways and sufficient free space should be provided. Conditions for accessibility of service areas, auxiliaries (WC, dining room) are the same as in case of general design for accessibility considering either the sizes or the equipments. Depending on the type of the workplace, accessible toilets should be installed according to the regulations on quantity by floor and by sex.

Special attention should be paid to furniture. For ensuring the right sitting position, you must avoid: leaning of the head or body, lifting of the upper arms, side positions, staying in the same position for long period, support on sensitive parts of the body. Adjustable height, mobile, well-designed backrest (following the shape of the back), footrest, adjustable armrest and waist support can facilitate sitting in the right position.

The feet are the bases; all other things should be measured to them: the height of the desk and the chair (knees in 90°), armrest, waist support and the location of the monitor. The chair should be rolling or stable depending on the condition of the person.



7.8. To prevent problems (e.g. decubitus) the chair of employees must be well designed

7.4. Self-service areas



7.9. The operative parts of the machines that must be reached should not be higher than 120 cm.

The guarantee that the services located in the “self service” areas are used both internally and externally can be assured by installing cash dispensers accessible for people on wheelchair. This is in the case of banks and post offices;

Other cash dispensers accessible for blind and partially blind people should be provided, too. They should also be endowed with Braille keyboard, characters in relief and sonorous systems. This is in the case of banks and post offices.



7.10. Group of public phones – one of them can be reached from wheelchair



7.11. ATM for blind people with tactile symbols and audio plug

7.5. Shops

Shops providing services should be designed for use by everybody. Not only the customers, but colleagues may be disabled persons and the accessible environment is indispensable to equally be at work. The approach surfaces to the entrances should be clean, even, not slippery and without floor-level differences.

Usually there are parking garages connected to the modern shopping centres (e.g. hypermarkets) to provide parking space for vehicles. The different storeys of the shopping centre can be reached using elevators.

There are pay slot-machines for clearing the parking fee. The machines should be installed in a way that enables wheelchair users to approach. The buttons of the machines, just like the buttons in the elevators, should be at no more than 140 cm from the floor, to facilitate wheelchair users and people with restricted height.

Entrance of the shops should not have stairs and thresholds. Nowadays it is common to have doors that are operated with automatic openers. The sensors of the openers should be set to sense even a wheelchair user. The speed of opening and closing should be timed enough to pass for slowly moving people. If the entrance is a revolving door a traditional door should be designed next to it. The entrances of the

shops are generally made of glass, such as the connecting walls or display windows. The lower part of the glass doors and walls should have anti-bashing metal covering up to the height of the footboard of a wheelchair. The glazing doors must be made visible with marking or by other means.

Shopping baskets or carriages that can be connected to a wheelchair helps disabled customers.



7.12, Trolley for wheelchair users

The shelves should be filled with goods in such way that a person sitting in a wheelchair would be able to reach them. It is recommended to arrange the goods in horizontal units.

Shelves should be equipped with rims, where the information on goods can be written and can prevent goods from slipping down. If possible, tilted and transparent shelves at higher levels are recommended for better visibility of the stock.

Automatic scales should be placed at 120 cm, directly at the end of the counter

The height of the service counters with display windows should not be more than 145 cm in order to be able to see the stock from a wheelchair. For receiving the goods sold, a lower counter is needed: its height should not be more than 120 cm. It is also necessary to install a lower shelf at around 45-50 cm (knee-height of a person in a wheelchair) for putting the basket down.

A wheelchair friendly cash desk and counter should be provided for wheelchair user customers for after shopping. The height of the counter should be 70 - 100 cm. The width of the passage should be at least 100 cm in order to provide space for an escort person if necessary. The approach and passage at the cash-desk should be straightforward.

After shopping, packing of the goods can be done on a counter providing free space for the legs

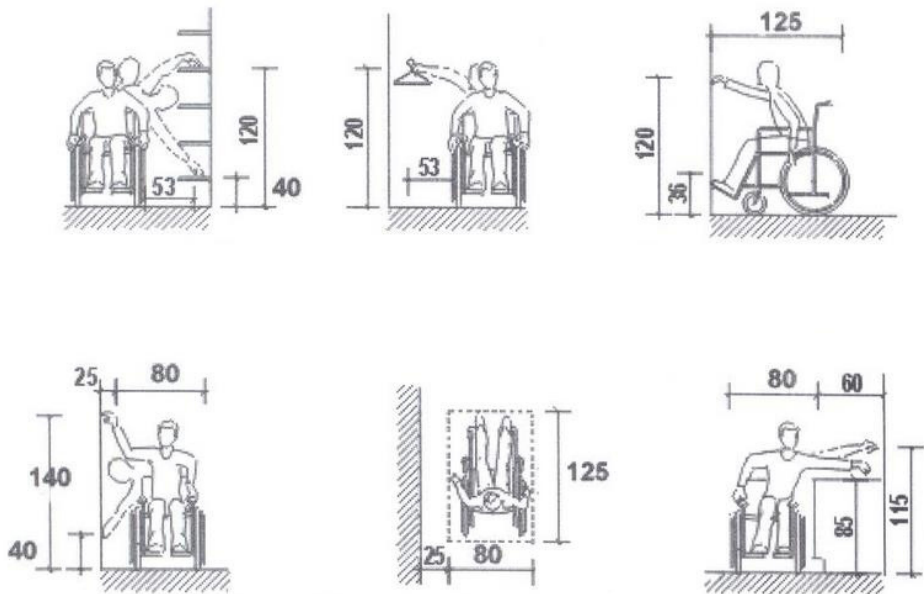

7.13. Spatial limits of accessible shelves and counters

Cloth racks should be at an adequate height in order to reach the goods from a wheelchair (max. 75-80 cm). In the case of clothing, a fitting room is required.



7.14. Cloth racks should be at an adequate height

At least one fitting room should be suitable for wheelchair users. The necessary turning space of 150 x 150 cm, with fixed mirrors at the back and one side, grab bars and a bench should be provided. A coat hook should be installed at maximum 120 cm.

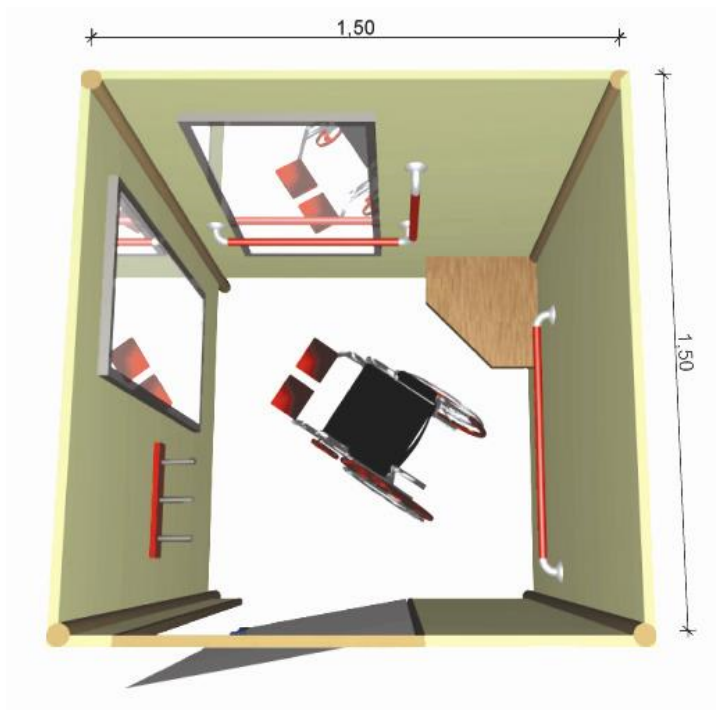

7.15. Accessible fitting room

8. Visual and tactile information

Many people use assistive device to correct their visual impairment. The pair of glasses is so common that nobody consider the spectacled people impaired because due to the correction by lenses one can see, read and orientate well.

Nevertheless there are visually impaired persons which even if using glasses (sometimes strange ones) cannot clearly perceive the visual environment, cannot read text or interpret symbols unless we amplify the information or substitute the visual with tactile information. Amplified visual information helps for people with low vision. Each measure, indispensable for visually impaired makes easier and comfortable the life of the others!

Amplified visual information do not help the blind people – they need tactile (and acoustic, where relevant and possible) information. Tactile information is indispensable for blinds, and makes easier the orientation and safer the environment for visually impaired. In general visual and tactile information should be applied together.

8.1. Amplified visual information

There are different types and different levels of visual impairments. The visual acuity is expressed on a scale (the term is originated from Latin), where 1 correspond the normal perception, 0 expresses the blindness. Below 0,1 the perception maybe restricted to recognise light and darkness and some obscure patches. Remember that it is measured when the person uses his/her glasses!

A special visual impairment is the colour vision defect and its heaviest version, the colour blindness. Those living with this impairment may have no problem with their visual acuity, but mix or absolutely do not perceive the colours: for the colour blinded people the world is black, grey and white. Others see only a limited sector, like looking through a tube and perceive only a small part of the environment. They do not see a complete picture seeing only a "gun-barrel" visual field they can imagine the environment only. They scan, perceive small puzzles and put together the lasts in fantasy.

Similar fast scanning should be done by those who do not see the central area, only the periphery of the environment. Other illness is characterised by several patches in the visual field.

There are different ways to augment of visual information: the size and forms of letters and symbols, the colours of them, their background and the environment and last but not least the light – all can promote the perception or prevent it.

Characters are easy to read if they have not too fat or thin shape (width-to-height ratio: 3:5-1:1),

- characters should have a normal stroke width (stroke width-to-height ratio: 1:5-1:10) and have uniform stroke width, colour and sharp, not rounded edges (like Arial, Verdana)
- normal character spacing is easy to read, dense writing makes it more difficult
- displays that build up the characters of dots are the most difficult to read for persons with visual impairments, classical digital numbers and letters are also hard to identify

There are signs and symbols of special importance: like emergency exit, evacuation way, fire signal, help point – in general security and safety signs. Their easy perception may be the question of life or death! Sloppiness, frumpish work, careless maintenance may make somebody victim, others killer! Besides of all measures, mentioned before here one more technique, the animation of the symbol can be applied. This is not only eye-catching for everybody, but an important way of communication for people with hearing impairment.

Perception of the interior is easier for persons with low vision if flooring, walls, carpets, door frames, ceiling have contrasting colours.



8.1. Contrasting colours make easier the orientation

Safe perception and orientation can be helped by guiding lines and good non dazzling and not mirroring lighting (with disposition referring to the paths). A circulation system is accessible if conscious use of different architectural tools like colouring, surface changes, lighting, information signs) are considered.



8.2. This door handle is easy to see, easy to grip

Walking along the corridor the doors can easier be found, if their colour, those of the frame and wall are contrasting. The same applies for the small elements as well.

Marking the contour of the area, swept by the door prevents accidents. The door can be opened suddenly and unexpected; it can be automatic when one does not know the direction of the opening. This solution is in favour of all.



8.3. Marking the floor area swept by the door



8.4. Visual marking the glazed door prevents accidents

The glazed doors must visually be well marked; otherwise it is not easy to percept whether it is open or closed.

Handrails, their ends, the edges of the first and last steps should be marked with contrasting colours

Entering a building where we are visitor, client or guest, first we are looking for information: who is where, which service is in which room. Maybe in the lobby there is a kind receptionist, full of keenness to help us – maybe not. Even if yes we may prefer to solve our problems alone independently, without relying on others' support. Providing the information signs meet the requirement we learn, where to go. In a multi-storey building we can chose the stairs or the elevator. Appropriate marking of stairs makes easier the task. Using the elevator we have to activate it using the control panel.



8.5. Tactile control panel in the elevator

On this control panel not only the usual letters,

figures and symbols can be perceived by touching the buttons: the information is written with the Braille alphabet, too.

Tactile characters should be embossed by min. 1mm, their height should be between 1,5-4 cm. Tactile texts may be emphasized by lights that make shadows and so will be easier to read.

It is preferable to confirm the information, already got in the lobby, what is on which floor? The buttons on the control panel must be detectable, perceptible and arranged in a logic system: e.g. those of floors in vertical, door opening/closing separately, emergency bell squarely differentiated.

"Visibility dots" in a single colour environment or on a glazed door are simple but efficient eye-catching means.

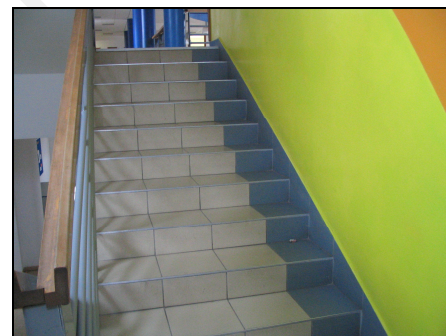

8.6. Visibility dots and marking of the edges of stairs

8.2. Orientation of blind people

Whilst a person with low vision needs amplified signs (in size, colour and contrast), blind people should be helped by signs detectable by touching, or by acoustical information.

Touching a sign – the so called tactile information – is possible by

- feet: the material and the texture of floor covering can be felt through the shoes
- the white cane: the symbol of blind people,
- finger: bilged symbols (e.g. door opening in an elevator cabin), a bilged simple number, a bilged layout, text, written with Braille alphabet, model of the environment.

Tactile information by feet and white cane facilitate to follow a way, to recognise the change of direction or arrival to a specific point, e.g. a door. Tactile information by finger is to realise a symbol (e.g. in an elevator cabin), to read a text (e.g. which office is behind the door), to imagine an environment (e.g. a bilged layout, a model).

Tactile information may, and wherever possible should – be complemented by acoustic information: “living voice” is incidental, but recorded text can be provided automatically, e.g. to announce the next stop of public transport, the direction and floor number of elevator. More developed system may be activated by sensors: e.g. when you are approaching an information table, you can get a message that the tactile map is on the wall in front of you or on your left/right. People with impaired vision and typically elderly persons need good quality voice information to be able to follow and understand it. Amplification, good acoustic environment and use of special equipment help accessibility and access to information. An environment which has no good acoustic characteristics may make impossible the understanding spoken information. Elimination or minimisation of background noise is difficult, but necessary to percept spoken information. Neither the “soft”, nor the “hard” acoustic environment is favourable. Good reverb time is the base of good acoustics: reverb time is ideal if it is 0,2-0,5s (too short time results a studio like environment, too long time means disturbing, long-lasting reverbs).

Regarding the space and safe walking within a building there are some special requirements:

- person using a white cane requires 90 cm clear width (for scanning with the white cane),
- while using a white cane only objects less than 70 cm from floor level can be safely detected, above this height protruding objects can be dangerous: if they extend more than 10 cm from the wall, there is a great risk of walking to them and get hit,
- hanging objects lower than 2,00m from floor level can be hit by the head of the walking person and be dangerous,
- orientation and perception is easier if there is a guiding rail 0,90 -1,00 m above floor level.

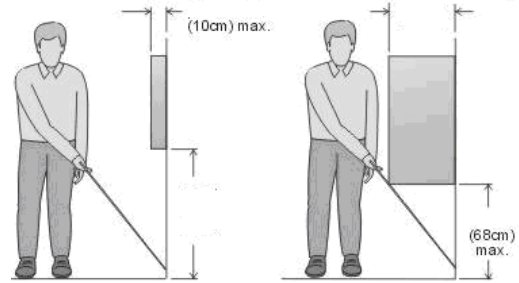
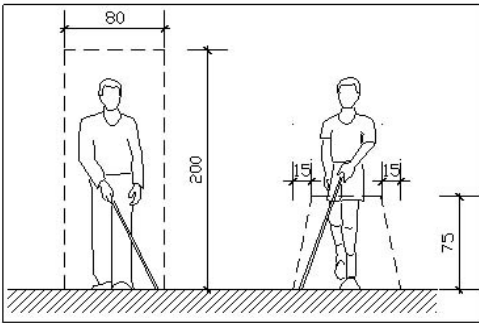

8.7. The perceived space with white cane

There are two kinds of white cane: the “marking cane” which does not differ from a “normal” one, excepting its white colour and the long cane which facilitates to touch the floor, to follow a line, to percept tactile message from the floor, to percept obstructions.

For blinds as well as for those having problematic gait all thresholds, surface damages and creased carpets increase the risk of tripping over.

Would something be mounted on the wall for the use of everybody (e.g. a public phone) the blinds should be guided to it using tactile information on the floor.

If a blind person intends to use this object the approach is perpendicular to the wall. Even in this case he/she should know where to stop. The „message” can be got through the long cane from the wall. Would it be too late due to the size of the object, marking on the floor level is to be provided. This marking should follow the vertical projection of the contour of the object.



8.8, Moving forward with white cane

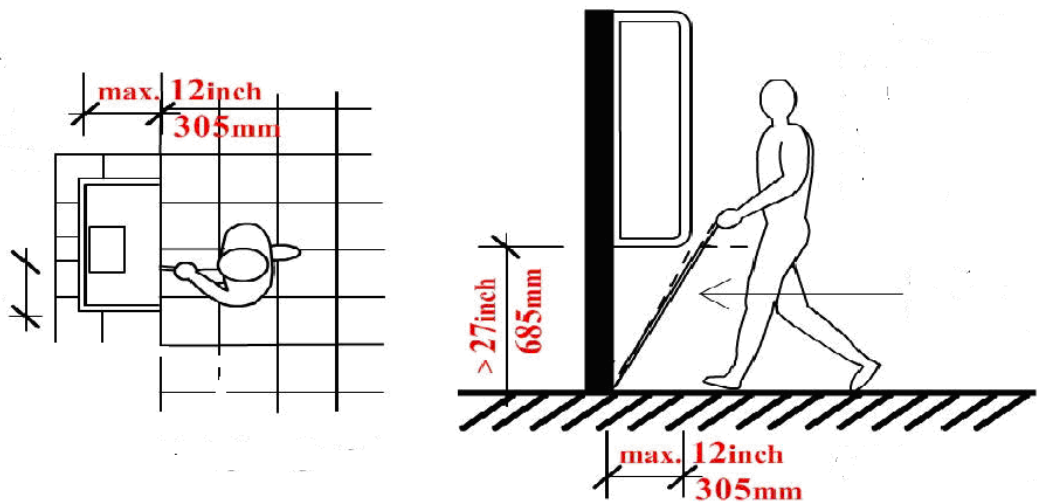

8.9. Approach a protruding object on the wall

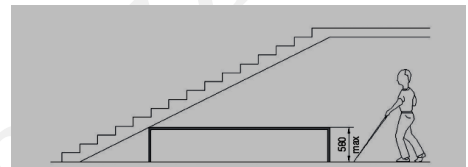
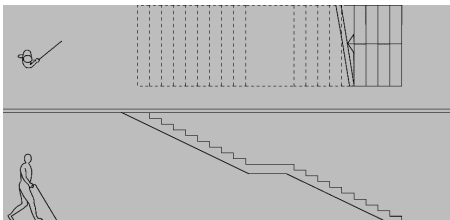

8.10. A special risk of accident



8.11. Prevention of accident

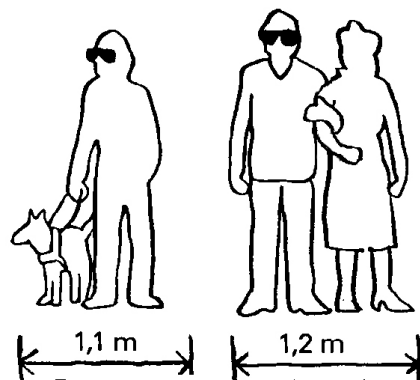

8.12. Space requirement of blinds

A special problem is a stair which starts from the actual floor. The injury should be prevented by obstacles below the stair, perceptible by white cane.

Blind people may rely on assistance. The assistant may be a person or a specially trained guiding dog. In both cases the movement requires extra space.

8.3. Tactile floor covering

Tactile floor covering is applied on both indoor and outdoor areas. Tactile information on the floor may be provided using the same material (tiles) with

different texture. The texture is felt by the feet and characteristic versions (parallel ribbed) or point-like markings can be palpated by the white cane, too.

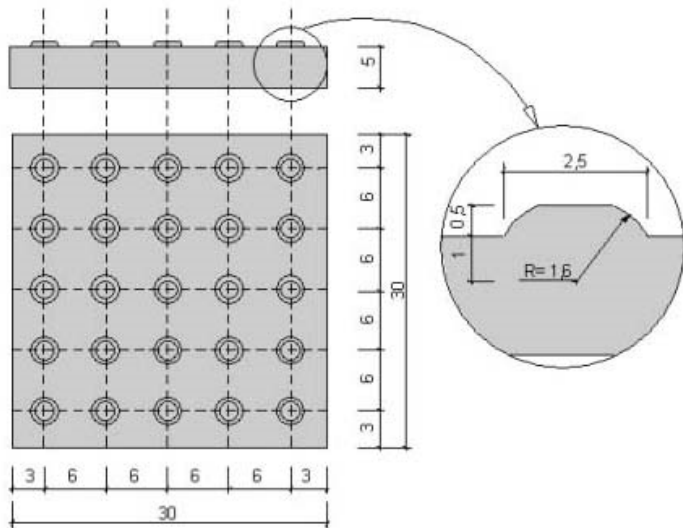

8.13. Plan and profile of a tactile plate and part of flattened semi-sphere

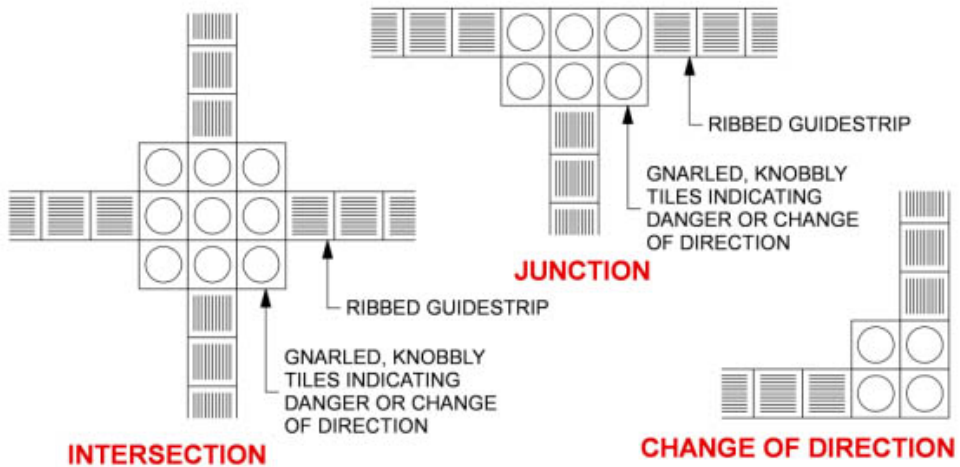

The colour and pattern of the tactile alignment strips differ from the surrounding surfaces. Danger occurring because of intersection or change of direction is indicated by different path surfaces.

8.14. Principles of forming the guide strips on pedestrian paths

The layout of the routes is “drawn” on the floor with different tiles.



8.15. The change of direction is marked by different texture. The new direction can be felt on the tiles – here no options are offered. It is to be mentioned that the right angle can be felt well by the majority of blind people



8.16. Marking a possible destination: you can follow the route, but you can turn to the left, where you arrive to a possible destination and you should stop. The destination may be a door, an equipment like a public phone, an information table or desk or even an urinal

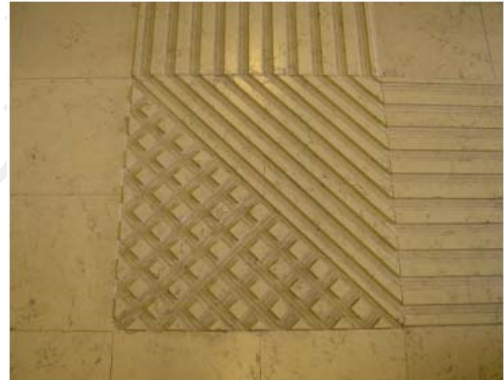

8.17. The change of direction is marked by a special texture

The route may be curved, according to the layout of the space. Nevertheless it is to be mentioned that it is easier to follow straight lines and right angled change of direction than a curved route.

Guiding lanes may be formed by using of different materials on the floor, e.g. carpet on tiles or parquet. It is very important to prevent the creasing of carpets along the edges which would increase the risk of tripping over – not only in case of blinds but people with low vision or impaired gait. The change of the material means that the straight and barrier free walk should be changed, some new situation is to be expected –e.g. it marks that you are approaching a door. Such a mark should be at least as long as an average



8.18. Wherever an option is to be selected (to go straight forward or making a turn where there is a door the lane is interrupted and triangles show the changing – optional – direction.

step (60-80 cm), so the perception of the tactile message becomes inevitable (you cannot step over the mark).

Tactile and contrasting floor covering shall be provided at the landing of ramps and stairs. The length must exceed that of a step (60 cm).

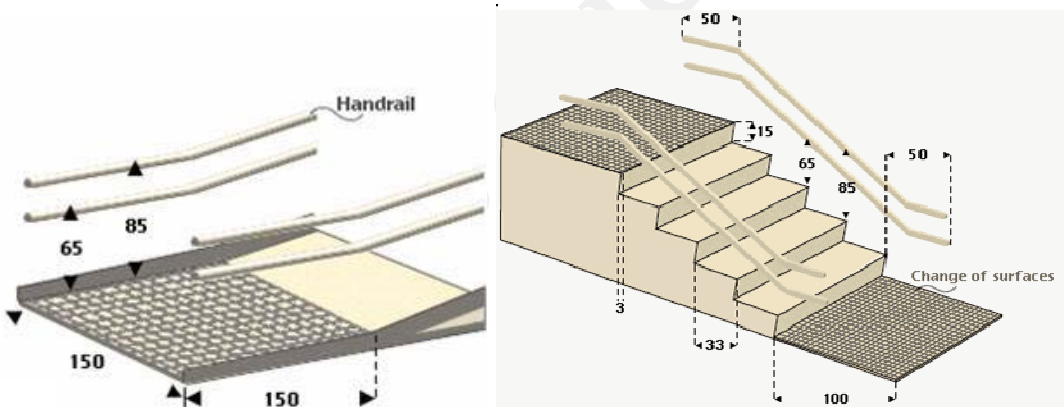

8.19. Changing horizontal floor for a ramp or stair must be marked visually and with tactile floor covering

Metallic elements (“passage clouté”) are applied, too, although they are disliked by many people of low vision.

An important role of tactile covering is the marking of the curbed ramps at street crossing: this is the only mean to call the attention of blind people that one more step and they will be on the street.



8.20. Marking the danger: tactile lane along the edge of the tube station



8.21. Tactile marking at street crossing shows the end of curbed ramp.

8.4. Other types of tactile marking

Tactile information: symbols, text with “normal” characters and Braille alphabet can be provided anywhere.



8.22. Tactile symbol on the door



8.23. The text repeated in Braille writing

Example of an information panel, the same text is repeated with Braille letters.

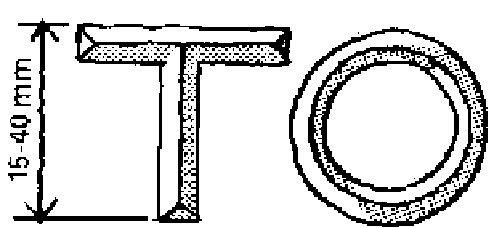

8.24. Thickness of the character 1,5-2 mm

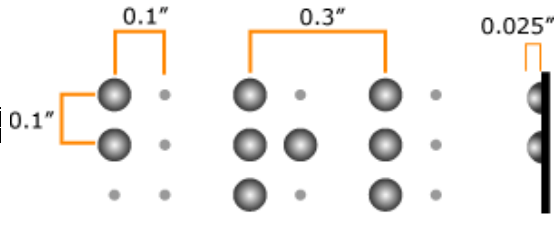

8.25. The scheme of Braille characters

Blind people use Braille signs for reading and (using a simple machine) writing. One letter or number occupies a rectangle where dots may be put, minimum one, and maximum six. Each combination of the number and position of dots in a rectangle corresponds to a letter or number. The dots are bilged, either on paper or on other material. Touching them by finger blind person can read anything. Not all blind people can read the Braille alphabet and even if yes, perception of tactile symbols (e.g. door closing) is faster and simpler than to read 11 characters in the given example, so whenever possible a rational combination of tactile symbols and Braille alphabet should be used.

Braille characters have a standard size requirement; other versions are more difficult to read:

- dot diameter: 1,5mm,
- inter-dot spacing: 2,5mm,
- horizontal separation: 9; 9; 6mm
- vertical separation: 10mm

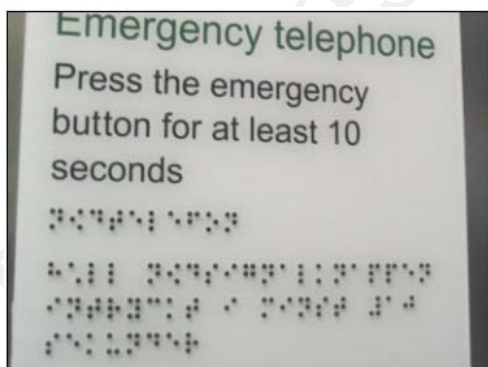

8.26. Information panel



8.27. Tactile information on the handrail

In a public space Braille characters has to be made of material that keeps its form and is not destroyed by moisture, temperature changes or sunshine. Self intended Braille signs must be placed at an accessible reaching height .

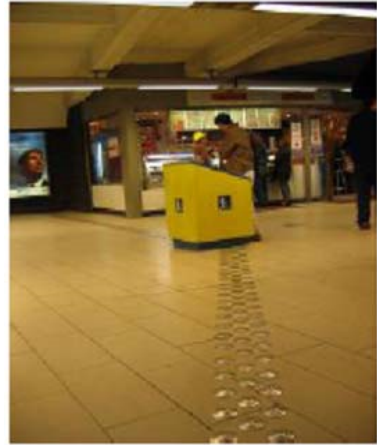

8.28. Tactile information panel in an underground station – tactile lanes guide to the information counter.



8.29. Tactile map

9. Safety in use, emergency evacuation.

9.1. Basic considerations

Surface is defined as the material on which a person walks or wheels in the inner or outer environment. The type of surface often determines how difficult an area is to negotiate. Most guidelines for accessibility define accessible surfaces as *firm, stable and slip-resistant*. Firm and stable surfaces resist deformation, especially by indentation or the movement of objects. A surface such as concrete, resists indentation from the forces applied by a walking person's feet and reduces the rolling resistance. A slip-resistant surface provides enough frictional counterforce to the forces exerted in ambulation to permit effective travel. We have to consider circumstances in which the people will move over surface:

- dry or wet due to cleaning,
- influence of cleaning agents and waxing
- outside conditions (rain, snow, frost)
- a layer of dry leaves in autumn, ...

Wood floors can be traversed without much difficulty by most people, while a gravel surface can be impossible for some people, especially wheelchair users, to cross. Outside surfaces are generally concrete or asphalt but commonly include tile, stone, and brick. Inside surfaces can be also wood, carpet and rubber or similar materials. Cushioned carpeting is not recommended as a springy surface does not offer a firm, stable foothold and deep-pile carpet causes resistance for those with a shuffling gait, risking a stumble. This type of carpet can also be a hazard for people using walking aids.

A change of surface material can cause a danger and should be indicated. Often floor surfaces do not meet the slip resistant requirements making them hazardous for pedestrians to walk on, particularly people with mobility disabilities. Highly polished surfaces can indicate that the slip resistance rating has not been achieved, especially when people entering a building have wet feet. Managers of buildings usually resort to the provision of a strip of carpet or a mat immediately inside the entry to dry soles of shoes before coming in contact with the floor surface. These mats can themselves become an access problem if not secure, particularly for people who are blind or vision impaired.

Changes in level are defined as vertical height transitions between adjacent surfaces or along the surface of a path. In the sidewalk environment, curbs without curb ramps and dislocations in the surface material are common examples of changes in level. They also can result at expansion joints between elements such as curb ramps and gutters. Changes in level can cause ambulatory pedestrians to trip or catch the

casters of a manual wheelchair, causing the chair to come to an abrupt stop. People who are blind or who have low vision might not anticipate changes in level such as a buckling brick sidewalk.

In buildings changes in level are overcome by stairs and ramps. Their height is limited and has to be interrupted with landings. Stairs need to have straight flights. Steps must have consistent dimension throughout the whole flight. Shape of steps has to be appropriate.

Handrails are important to all of us, but especially so for people who are blind or vision impaired, people who have a mobility disability (but are able to use stairs) and people who have an intellectual disability or brain injury. Handrails are used to steady and provide guidance as we ascend or descend the stairs. To ensure the stairway is as accessible as possible two handrails are required. This assists those people who don't have the use of both hands, in which case they may need to use either the left or right hand handrail as they ascend or descend.

Effective handrails are ergonomically designed so that they can be used by all people, especially those with an impairment to their hand or arm function. Continuous handrails that allow a user's hand to maintain a hold on the handrail without the fixings breaking the grip assists in safe transition throughout the complete journey either up or down a stairway. The ends of handrails must be designed to reduce the incidence of injury to pedestrians.

Handrails and kerfs or kerb rails on ramps are important to people with a range of disabilities, for example, people who are blind or vision impaired, people with a mobility disability and people who have an intellectual disability or brain injury. Two handrails are required as some people may not have the use of both hands in which case they may need to use either the left or right handrail. Kerb rails are required to reduce the chances of people who use wheelchairs running off the edge of the ramp or catching their toe plate behind the handrail supports and as a result tipping out of their chair.

The specifications relating to the ergonomic design of handrails ensure they can be used by all people, especially those with a disability that affects hand or arm function. Continuous handrails that allow a user's hand to maintain a continuous hold on the handrail assist in safe movement throughout the complete journey either up or down a ramp.

All sudden changes in floor level and vertical drops (sudden drops) have to be protected. For instance a sill of sufficient height prevents people from falling through the window. Railing on a balcony has the similar task.

Safety devices are essential for doors with automatic systems and should ensure that a person does not become trapped or pushed by any moving components. The door activation devices can be used as safety devices if they are able to detect stationary objects. Alternatively, additional safety features may be added, depending on the type of installation and expected use.

Passive safety devices include safety switches and pressure sensitive strips which, when contacted, prevent further movement of the door or a reversal of door movement.

Presence sensing devices, are the preferred type of safety device because they are able to interrupt door movement at any point during the door movement cycle if a person remains in the door opening. Presence sensors are able to detect stationary objects, and should therefore prevent doors from moving in the event that a person falls within the doorway.

Motion sensors, detect movement, but not stationary traffic. These devices will not prevent a door from closing if a person is positioned in the path of the door leaf and may not be able to detect people who are moving slowly in the doorway. They should therefore not be relied on as a safety override device.

Low energy swing doors are a particular category of automatic hinged doors. Due to their slow movement and consequent low kinetic energy they are not considered to be dangerous. Therefore are not fitted with the same elaborate safety mechanisms that other automatic doors require. The British Standard on low energy swing doors (BSI 1996 p5) defines them in terms of their minimum times for opening (from fully closed position to fully open position) and closing (from fully open position to fully closed position). These minimum opening and closing times vary from 4.5 seconds upwards

Consideration should be given to the fire-resistance qualities in products and buildings which are used by people with disabilities. Materials susceptible to ignition by a small source such as a cigarette, match or other small flame present a potential hazard if they continue to burn, producing toxic smoke or result in rapid growth of fire. People who cannot move quickly or who do not see well are in particular at greater risk.

9.2. Escape routes

In case of fire or other emergencies occupants of a building have to be able to evacuate to a place of safety. Design, layout and number of escape routes and exits depend on the number of occupants and their mobility. For rescue team's safe access to, search, and get out of the building has to be provided. In case of fire the safety of occupants during evacuation may be ensured by four types of measures:

- design and layout of escape routes in order to ensure safe evacuation of occupants to a place of safety,
- separation of escape routes from the surroundings by means of fire and smoke-separating elements,
- smoke control measures,
- limitation of fire and smoke generation from wall and ceiling linings and floor coverings in escape routes.



9.1. Signage of the accessible fire exit, elevator which can be operated by fire-men even in case of fire and refuge area.



9.2. Alarm signal must be at a height reachable from wheelchair

9.3. Directional sound emitter for blind people



9.4. The escape route should be marked on the floor level as well since the symbols in the usual position become invisible in a few minutes due to the smoke

Safety of occupants vitally depends on early fire detection and notification system. On the escape routes installations for way finding and safe retreat have to be provided:

- emergency lighting installations,
- emergency exit sign installations,
- emergency power supply installations serving fire safety installations,
- safety devices on doors (panic bars etc.),
- emergency guidance systems

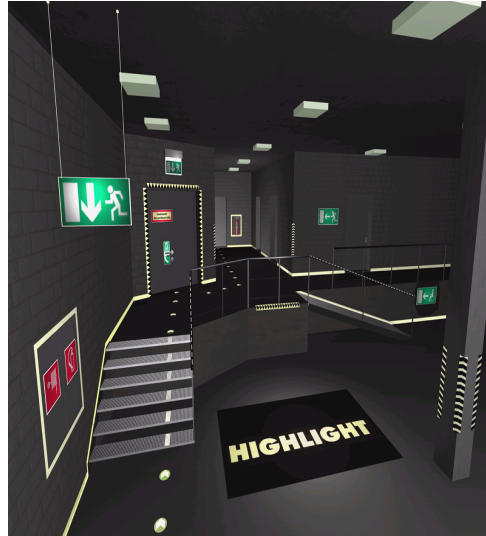
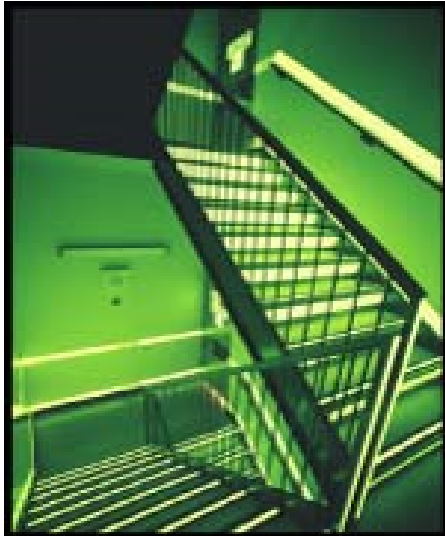

9.5. Luminescent marking of escape route on the floor level

Persons with motor disability can be wheelchair users with/without service animal, people with ambulatory disabilities (walking with crutches, stick, etc.), people with respiratory impairment etc. We can be sure that we avoided majority of the problems that a person with motor impairment might have during emergency evacuation on horizontal routes. Where not all the circulation paths can be used by people with motor disability, the usable ones should be clearly marked by the international symbol of accessibility.



9.6. The “safe place” can be a rescue area : a room with fire resistant walls and doors on each floor in a fire compartment where people can safely wait for the rescue team. The communication possibility between the rescue area and the firemen is to be provided.

For persons with visual impairment special attention has to be dedicated to way finding and evacuation on vertical routes, where fire protected elevator or assistance in proceeding down exit stairs might be required. Using existing elements within the building may help a visually impaired person to facilitate their own evacuation. Features of good building design with reasonable adjustments are good colour contrasting, handrails on escape stairs, contrast to the nosings on the stair



9.7. Escape route can be marked on handrails, too

treads, markings on escape stairs, colour contrasted or different texture floor coverings on escape routes, or way finding information. Usable emergency evacuation routes have to be clearly marked by appropriate tactile and Braille signs. Lettering has to be large enough and contrasted. Signs and communications must be placed above exit doors and near the ceiling. Tactile and Braille information has to be placed near the doors (where people with visual impairment can touch them). Powered way guidance lighting system can help partially sighted people when evacuating in addition to conventional overhead lighting. We can also consider sound guidance systems (sound beacons) to ease way finding and for quicker progressing along the evacuation route. Where audible signals are used, any potential interference by the fire alarm operation needs to be considered.

9.3. Doors on escape routes

Depending on the floor area and the number of stories the buildings are divided into fire compartments (areas enclosed within a fire-resistive construction). Passing from one to another compartment is possible through fire-proof doors. Rating of doors is defined in regulations and is usually rated at 30 minute fire resistance. The maximum distance a person must cross to reach the next compartment is also defined in the regulations. For impaired people sometimes distances and door ratings may have to be reconsidered. Some people can for instance walk just a short distance and then need a break, others move in a slower pace or need assistance, etc. The number and length of the escape routes depends on the function and height of the building and on the number of people within the building.

It is essential that devices for unlocking doors on escape routes can be operated by all users, including those with disabilities. Mechanisms which demand a lift-and-push or two-handed operation and those operated by turn buttons and smooth knobs are unsuited for people with dexterity and/or strength impairments. The height of unlocking mechanisms must suit people in wheelchairs and those of small stature.

Mechanisms with direct push operation, such as a push pad or lever handles are ideally suited to most users. Multi-point locking systems should be operated by a single turn of the key.



9.8. Emergency exit can be opened easily even by a wheelchair user



9.9. Example of electromagnetic hold-open device used to hold fire doors in corridor open while in normal use. Activation of the fire alarm or a power cut deactivates the electromagnetic hold-open device and the doors close under the action of standard door closers

Doors fitted with automatic operating systems may be designated as emergency exit routes. If so, they should be fitted with one of the following systems:

- a manual break-out facility which enables the doors to swing open in the direction of escape, or
- a linkage to the fire alarm system, set to incorporate a monitored fail-safe system — that is, the doors to open in the event that the alarm is activated or the power fails.

Self-closing fire doors in corridors tend to be a nuisance for all users but especially those with impaired mobility or impaired dexterity. They are also a nuisance for people whose hands are occupied carrying something and their opening and closing can be a danger to children and people with reduced mobility. The use of suitable devices, such as electromagnetic hold-open device as illustrated, should be considered for such doors. These allow the door to close automatically in the event of a fire so as not to compromise their fire safety function.

9.4. Evacuation chair



9.10. Evacuation chair in use

Near to the stair evacuation chairs can be stored on each storey. Providing assistance is available mobility impaired person can be evacuated in the evacuation chair. Descending on the stair the evacuation chair should be oriented but no pushing is necessary.

10. Outdoor environment

10.1. Sidewalks

Ideally, the sidewalk network that makes up a public pedestrian circulation system should permit passage to every address and pedestrian feature on or along every pedestrian route. The pedestrian route must be accessible. The minimum width of an unobstructed pathway should be 0.90 m.

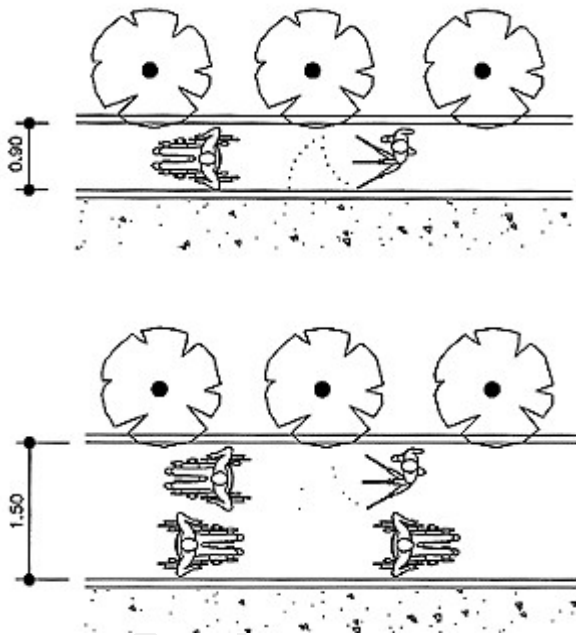

10.1. Minimum width of sidewalk

The minimum width of a two-way wheelchair traffic passage is 1.50 m. The preferable width is 1.80 m. It is also recommended that besides of the minimum of 150 cm wide with, a planting strip of 60 cm on local streets and in residential and commercial areas. It is also recommended that a planting strip of 50 cm is planted on local street and in residential and commercial areas in addition to the 150 cm width.

Because wheelchairs, like other wheeled vehicles, do not track within the same path when turning, additional length and width are necessary at turns. Because the length of a wheelchair space 120 cm exceeds its width of 75 cm, extra walkway width is necessary to turn and operate an entrance door, to approach and activate a pedestrian crossing signal button, or to enter or leave a kerb ramp.

Passing space for two wheelchairs can be provided in a space that is 150 cm wide, which is usually available at a corner, a driveway, or a building entrance requires passing spaces to be located at reasonable (preferably visible) intervals, not to

exceed 60 m, along accessible routes). Sidewalks that are at least 150 cm wide allow pedestrians to travel comfortably side-by-side and are the minimum convenient width for turning or passing. Some pedestrians who use crutches need as much as 100 cm in width to achieve a comfortable gait. An individual travelling with a service animal or sighted guide will use a minimum of 120 cm of width for easy passage. Narrow sidewalks immediately adjacent to street kerbs provide little margin for manoeuvring, particularly in crowds when line of sight is limited or when water, snow, or ice make control less precise.

Cross slope is necessary for water diversion, however excessive cross slope is a major barrier to travel along sidewalks for pedestrians who use wheelchairs, scooters, walkers and crutches, as well as pedestrians who have braces or lower-limb prostheses, and those with gait, balance, and stamina impairments. Energy that might otherwise be used in forward travel, must be expended to resist the

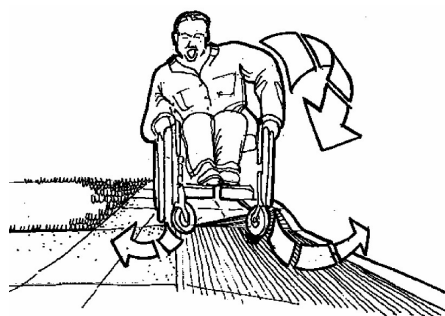

10.2. *The effect of cross slope*

perpendicular force of a cross slope along a travel route. Cross slopes that exceed 2% (1:48) significantly impede forward progress on an uphill slope and compromise control and balance in downhill travel and on turns. Because the cross slope of a sidewalk is typically toward the roadway, the pedestrian who loses traction or balance will be directed toward the street. In wet or freezing weather, travel across a slope always carries the threat of sliding into the roadway. Wheelchair users

whose upper trunk mobility is limited can be thrown from their seats by differentials in cross slope occurring over a small distance. Manual chairs, although more manoeuvrable than battery heavy power chairs, are much more likely to tip on compound slopes. When this happens, it is difficult to recover control, direction, and traction.

Pedestrians who use crutches are particularly susceptible to cross slope when they are travelling downhill. Children, including children with disabilities and those using bicycles and other wheeled toys, are primary users of sidewalks in residential areas and are significantly less able to compensate for cross slope than adults.

Driveway aprons in residential subdivisions where narrow sidewalks are immediately adjacent to the kerb are the most frequently encountered example of excessive cross slope along a pedestrian route. A level area with minimal cross slope is necessary for accessible passage across a driveway.

Driveway aprons that are constructed like ramps, with steep, short side flares, can render a section of sidewalk impassable, especially when encountered in series, as in residential neighbourhoods. Compound cross slopes, such as those that occur at the flares of a driveway apron or kerb ramp, may cause tipping and falling if one wheel of a chair loses contact with the ground or the tip of a walker or crutch cannot rest on a level area. A walker must have a flat plane to rest on if it is to provide adequate support.

Walkways that curve tightly while sloping are also problematic, requiring constant stroke or gait adjustment.

Sidewalk intersections in hilly terrain should be planned to avoid excessive cross slope toward the street. Where accessible sidewalks intersect at a corner, a level landing (2% in each travel direction) should result. Limiting cross slope requires careful attention to walkway design and construction to maintain positive drainage.

Where sidewalks of excessive cross slope are being reconstructed, it may be possible—if there is sufficient width—to provide a 90-cm continuous routing with a complying cross slope within the overall sidewalk width, blending adjacent surfaces to meet it.

A critical element of the drainage is the grating that have horizontal openings or gaps that exceed 12-13 mm in the direction of travel. Such gaps can capture the small front wheel of a wheelchair or the end of a crutch, suddenly stopping forward progress and possibly leading to a tip or fall.

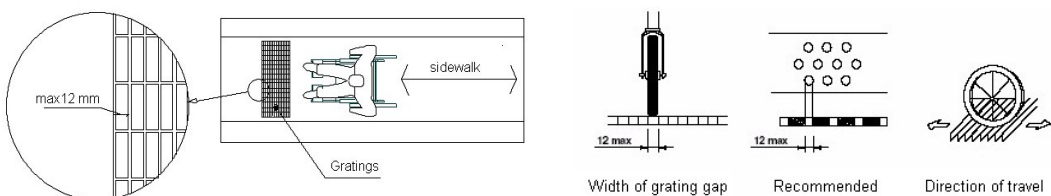

10.3. Problem of gratings

Gratings can be hazardous to wheelchair users, cane and crutch users, parents with prams and women with high heels. If possible, manholes, drains and gratings should generally be placed outside the pedestrian pathway. If it is not possible, the gratings should be flush with the pathway surface and should have narrow patterns of not more than 12 mm. Elongated grating openings should be perpendicular to the pedestrian travel path.

For changes in level of more than 13 mm between the pathway and the surrounding surface, guards, upstands or other types of barriers should be used.



10.4. Wheel guard along the route is necessary

Guards with a minimum height of 0.15 m should be used to separate pathways from planting areas, pools and landscape features.

10.2 Street furniture

The concept of street furniture includes different objects. The principle is to design accessible amenities convenient to all people, without obstructing the free passage of pedestrians along travel routes. Street furniture can provide a resting place for an individual with difficulty in walking distances. Such furniture should be located off pathways, to minimize its potential as an obstruction to pedestrians. Disabled and elderly pedestrians have expressed strong support for requiring benches at regular intervals along public streets, especially where sidewalks slope steeply. A level area should be provided for the bench. Pedestrians with disabilities will appreciate walkway seating with a fairly high seat, a shallow front-to-back dimension, a supportive back, and an armrest for making the transition between standing and sitting.

Garbage bins openings should be at an accessible height of approximately 0.90 m. Wheelchair-accessible and standing-height drinking fountains should also be combined when installed on public sidewalks, because there may be considerable distances between these fixtures.



10.5. Examples of street furniture

10.3 Kerb ramps

A kerb ramp or blended transition, or a combination of kerb ramps and blended transitions, shall connect the pedestrian access route to each pedestrian street crossing within the width of each crosswalk.

Standard cut back kerb ramps into the pavement with flared sides provides transition in three directions.

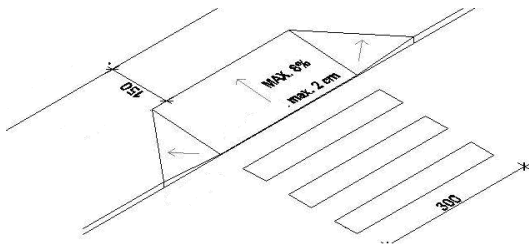

10.6. Perpendicular kerb ramp

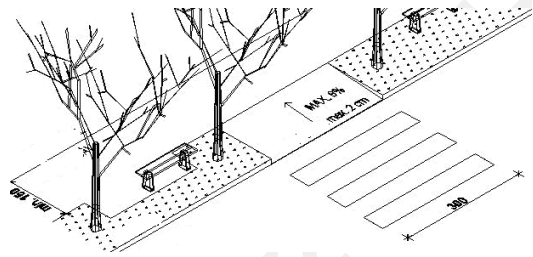

10.7. Returned kerb ramp

The familiar perpendicular kerb ramp (known as an inset, recessed, or returned ramp in some areas) cuts through a kerb line at right angles and is located within the border width. Such a ramp may have returned edges if it is in a parkway or landscape strip but should have flared sides so pedestrians may walk across them. Returned kerb ramps are providing slope in one direction. This could be a dangerous measure if the sides are not protected



10.8. Returned kerb ramp without side protection is dangerous for everybody

The diagonal kerb ramp, a variant of the perpendicular type (because it too cuts the kerb line at right angles), is located at the midpoint or apex of the kerb radius or return and serves two crossing directions with a single cut.

This solution seems to be rational (at street crossing four ramps enough instead of eight) however it is dangerous for wheelchair users.

If they follow the axis of the ramp they will be soon on the street in the traffic coming from any direction. If they try to arrive to the street level at right angle to the street axis thus they follow a route with a strong cross slope on the lower part of the ramp.

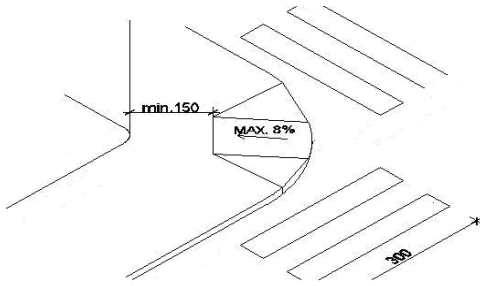

10.9. Diagonal kerb ramp

Where the construction of kerb ramps would affect the width of the travel route, the whole pavement should be lowered, at a maximum slope of 1:12, to provide the necessary level transition.

For narrow pavements lowered at a corner, the tactile tiling indicating the location of the pedestrian crossing could be constructed.

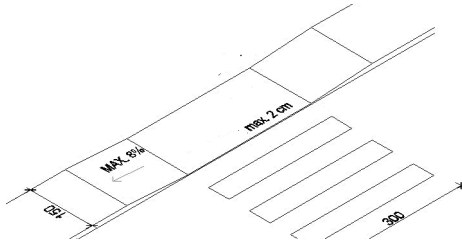

10.10. Solution for narrow pavements

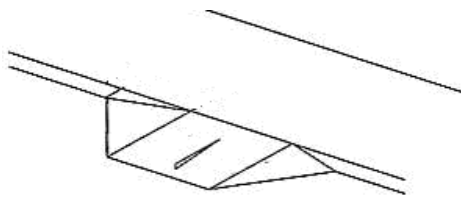
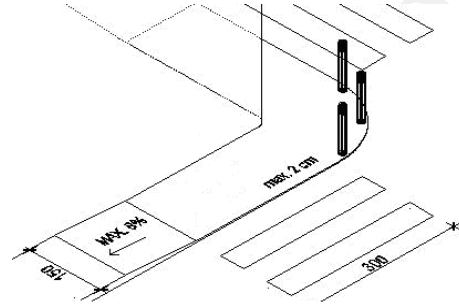

10.11. Built-up kerb ramp

The built - up kerb ramp usually with flared edges extends from the sidewalk and has edges that are blended down to the street surface with flared sides. Built-up ramps are a hazard to vehicles if installed in traffic lanes and do not provide edge protection for users, because their flares slope down to the adjacent road surface rather than up to the sidewalk surface.

10.4. Pedestrian crossings

The position of kerb ramps should be marked on the pavements. Pedestrians who have low vision will benefit from the marking of kerb ramp surfaces with a contrasting colour, texture, pattern, or other finish. The interest of wheelchair users and blind people are conflicting: whilst the kerb ramp is indispensable for wheelchair users blind people cannot perceive the kerb itself: they need tactile covering marking the border between the sidewalk and the carriageway.

Wheelchair users have also reported the effectiveness of a contrast in kerb ramp surface in identifying where an opposing kerb ramp meets the street, allowing pedestrians to travel quickly and directly across the roadway to an up-ramp. Where concrete paints or stains are used, care must be taken to ensure a slip-resistant surface, particularly when wet

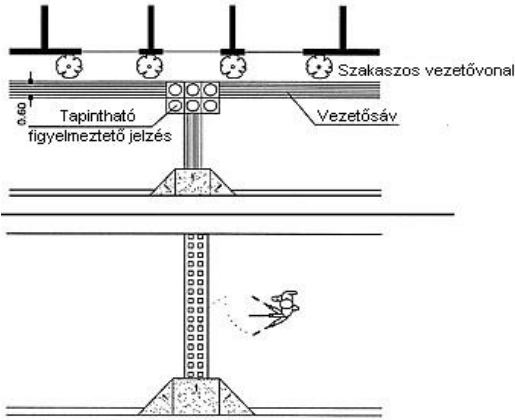

10.12. Marking the position of kerb ramp on the sidewalk.

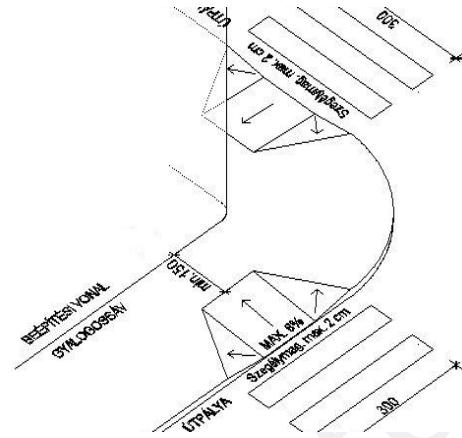

10.13. Kerb ramps at the corner: try to avoid the diagonal scheme

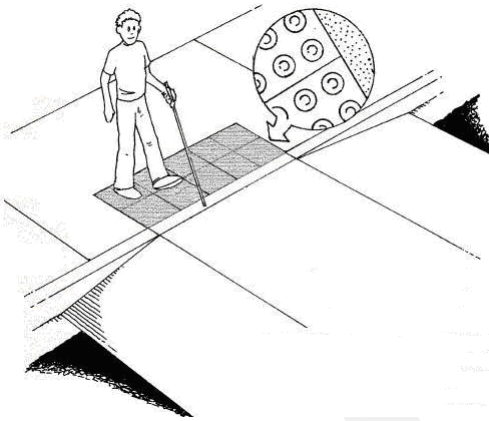

10.14. Raised crosswalks

Raised crosswalks continue across a street at kerb height. In this case tactile information must be applied for pedestrians with visual impairments. Marking the edges of the crosswalk is advisable.

Wide streets can be crossed in two phases. In the middle raised traffic island provides the refuge area where the next phase can be waited.

More comfortable is to wait between the road islands.

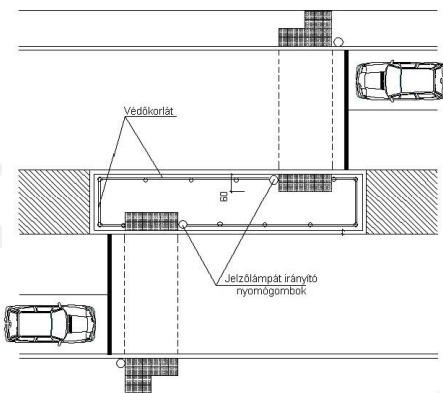

10.15. Raised traffic island

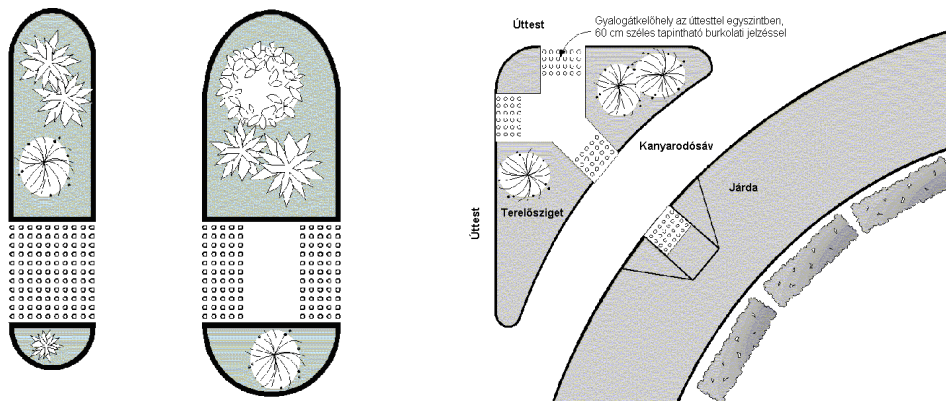

10.16. Refuge area between road islands: its edges or its full area have tactile marking.

Because the length of an occupied wheelchair is 1200 mm, a cut-through median should provide some additional manoeuvring length for safe refuge from traffic. A 1500 mm pedestrian space will accommodate longer wheelchairs and scooters more comfortably. Raised islands that are cut through may limit wheelchair travel to a single user per crossing cycle.

Where two signal cycles are required to complete a crossing, pedestrians with vision impairments should be advised with audible or other signals of the need to wait for the next crossing interval. A locator tone in the pushbutton on the median can provide this information.

Where a pushbutton or other operable device is provided for the use of pedestrians, the mechanism should not require more than 22.2 N of force to activate. Because outdoor devices will often be used by pedestrians who are wearing gloves or whose movements may be restricted by bulky clothing, it is advisable to select the largest available pushbutton or bar dimension - a 50 mm minimum is recommended - and to ensure that it is raised above the surrounding surface for ease of operation.

Devices that can be operated by a closed fist acting on any point on the surface will be most usable by pedestrians who have mobility impairments.

Pedestrian signal controls should be located within reasonable proximity of the kerb ramp and crosswalk. The bar or button should be mounted within allowable reach ranges for pedestrians who use wheelchairs. A height of 1065 mm - the height required for elevator buttons - is recommended. Pedestrians who use wheelchairs should be able to operate the button from a level landing rather than the sloped surface of a ramp.

There should be a 760 mm X 1220 mm level ground surface centred on each control for a forward or side approach, as appropriate. If a forward approach is provided, the button should be located in the same vertical plane as the leading edge of the clear

ground space; if a side approach is planned, the clear ground space should be within 255 mm horizontally of the button.

Pedestrians who are blind should not have to travel more than a few steps to operate a button and then return to the kerb to orient themselves for the crossing. It should be clear, by button location and associated tactile signage, which crossing direction is controlled; buttons for different crossings should not be mounted on the same face of a pole, and should be on separate standards if possible. A mounting pole may be used to shield the side of a kerb ramp in place of a flared side



10.17. Push button at pedestrian crossing

Pedestrians who are blind use audible and tactile information in independent travel. Although audible crossing indicators have been available for over 20 years, they have not been well received everywhere by traffic planners. This is probably attributable to two factors:

- noise pollution and consequent community opposition and
- disagreement among blind people on the need for audible pedestrian signals



10.18. The acceptable gap along rails

There can be rails on the street. The inevitable gaps along the rails must not exceed 60 mm.

10.5. Parking

It is considered (and stipulated by law) that the ratio of disabled people able to drive an adapted car is of 1:50, therefore:

- for parking facilities of less than 50 cars, at least one accessible parking space should be provided in every parking facility;
 - for parking facilities of a maximum number of 400 spaces, accessible parking spaces should at least be provided in the ratio of 1:50 (one accessible space for every 50 spaces);
 - for parking facilities of more than 400 spaces, at least 8 accessible parking spaces should be provided plus 1 space for each additional increment of 100 cars over 400. According to their position – indoor and outdoor – the accessible parking spaces should be located as follows:
 - for outdoor parking, not more than 50 m from accessible building entrances;
 - for indoor parking, right next to accessible elevators, or as close as possible to exits.
- The minimum width of an accessible parking space is 3.60 m. The recommended width is 3.90 m.

Concerning parking kerbs, two situations may occur in practice. If a kerb exists, kerb ramps should be provided to link accessible parking spaces to accessible pathways. If no kerb exists, a textured surface at least 0.60 m wide is needed to separate the

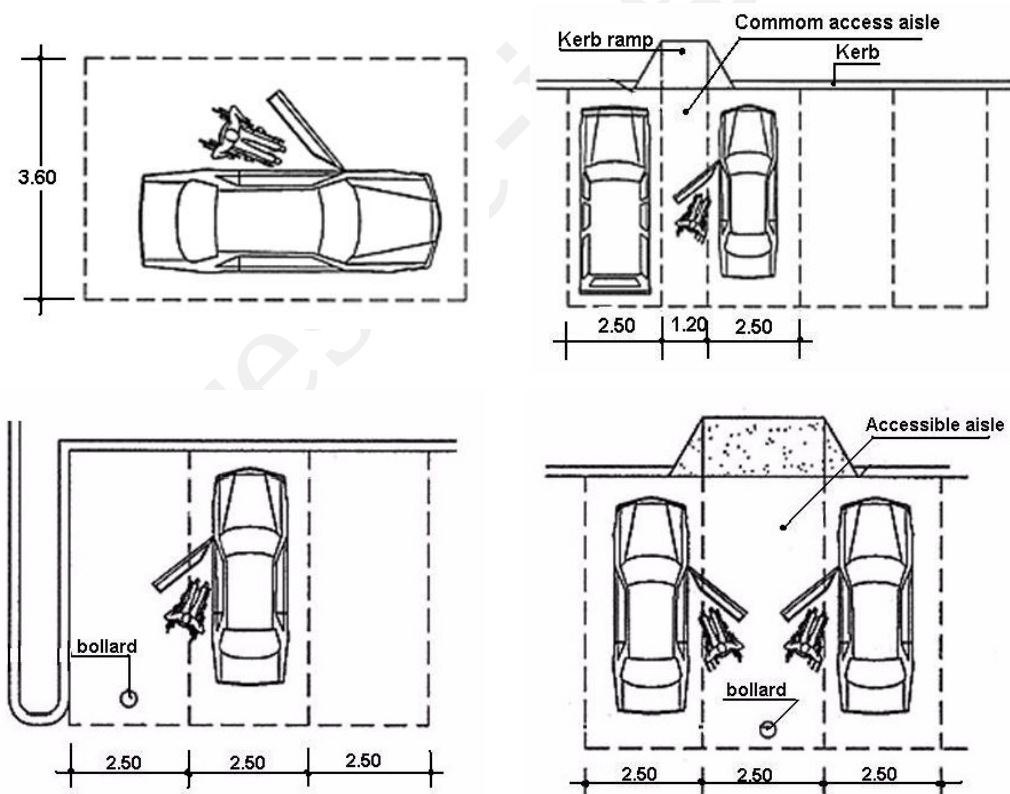

10.19. Space requirement for parking at right angle

pathway from the vehicular area; otherwise bollards should be used. Pre-cast wheel stops can also be used to set apart a passage at least 0.90 m wide.

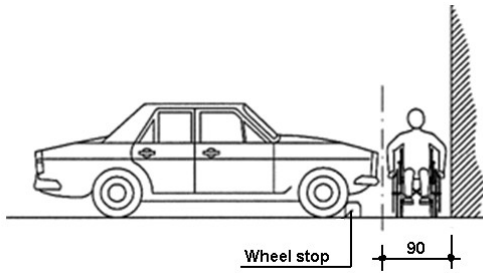

10.20. Wheel-stop provides accessible route between the car and the building

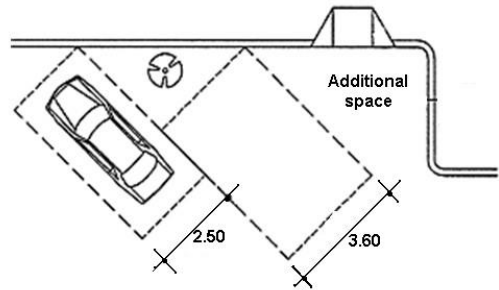

10.21. Arrangement of parking in diagonal position

Accessible parking facility should be clearly marked on the street surface and in eye-level height.



10.22. Example of accessible outdoor parking area

11. Public transport

Accessible public transport depends on three elements: information, vehicle and infrastructure. Information can be provided in several ways: visual and audio message to mobile phone, both in and on the vehicle and any form, including tactile maps at the stations and stops. Basic and real time information are possible.

As far as the vehicles are concerned the questions are the getting on and off and the safe and comfortable position during the travel.

The infrastructure includes the stops and stations: here the general rules of accessible design should be applied.

Harmonisation of vehicles and infrastructure is of fundamental importance: e.g. bus adjusted to stop or stop adjusted to bus or interim solutions.

Last but not least the training of the personnel is to be mentioned.

11.1. Trams



11.1. Harmonisation of infrastructure and vehicles



11.2. Low floor tram with drop-leaf ramp



11.3. Low floor tram is Strassbourg

Tram stop is often in the middle of the street; usually it has as a platform - a refuge area - of a similar height to that of the sidewalk (e.g. 10 cm), and sometimes has no



11.4. Stop of low floor tram with accessible information column and ticketing machine



11.5. Tactile and visual marking along the edge of the platform and to the door.

platform at all. The latter requires extra care for the boarding and alighting passengers and for the other traffic to avoid accidents.



11.6. Marking of doors on the platform accelerates the traffic

Having a unified vehicle fleet the place of the door can be precisely marked on the platform.

11.2. Bus

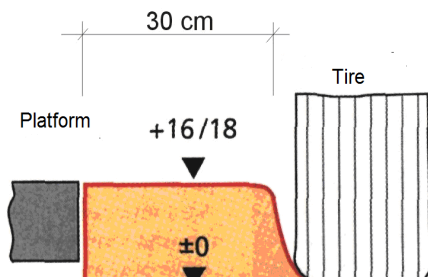

11.7. Special kerb profile minimize the damage of the tire



11.8. Steep collapsible ramp does not facilitate the safe and self-sufficient use of bus.



11.9. Contrasting grab bars and safety belt

Low floor buses improve access for disabled people, but full benefit will only be attained if bus stops are also designed to meet their needs.

Many bus stops have to be placed in locations where pavement space is limited but, where space permits, the following guidelines are suggested:

Bus stops shall:

- incorporate a paved, firm, level surface, in compliance with local authority standards,
- use adequate tactile markings
- not be impeded by adjacent street furniture, such as dispensers, vending machines, waste boxes, planters, posts, signs and guy wires.

Wherever possible shelter or canopy and bench should be provided.

The space requirement is shocking. The length of the ramp depends on the level difference between the bus floor and the platform – the slope should not exceed 8%. It can be seen where the lower edge of the ramp is. The wheelchair should be there:

add the length of the wheelchair plus maybe the space for an assistant person.

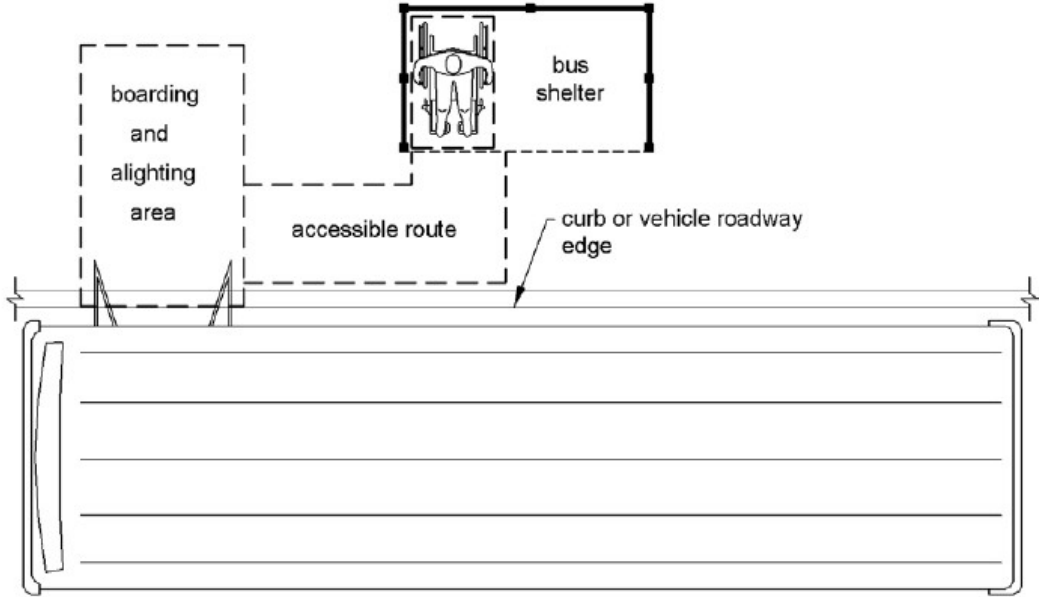

11.10. The layout of an accessible bus stop

11.3. Coach

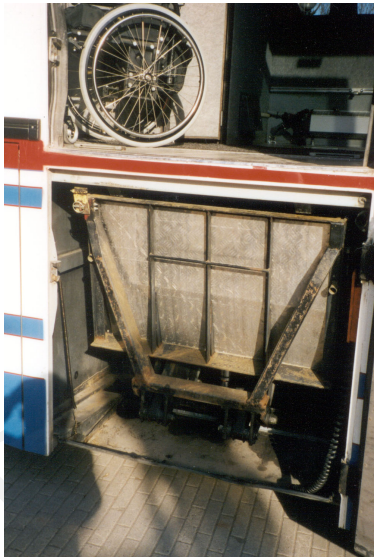

11.11. Platform lit of a coach



11.12. The platform lit in use

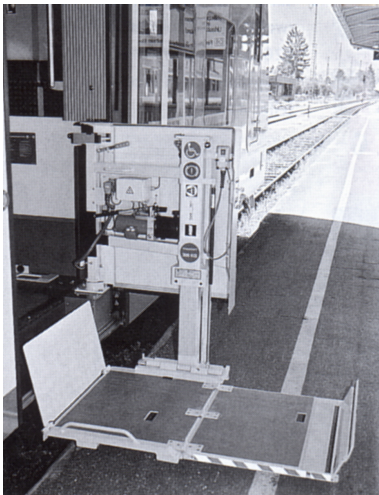

*11.13. Platform lit on the door:
applicable on bus and train*



*11.14. Fixation of wheelchair is of high importance
first of all on fast vehicles*

11.4. Train

Getting on and off traditionally mobile platform lifts are used on railway stations. Nevertheless the railway carriage itself may have platform lift.

For long-lasting routes other services are necessary. The most important one is possible: with some compromise in the carriage accessible WC can be provided.



11.15. Platform lift under the floor of the carriage



11.16. Entrance and cubicle of accessible WC



11.17. Behind the double door there are hydraulic lifting platform on both sides of the carriage



11.18. Collapsible seats provide free place



11.19. WC with grab bars and emergency call

The design and the details of railway station should follow the general rules of the universal design. A few details of a ticketing office are shown on Figs. 11.20. and 11.21.



11.20. Knee-free counter in a ticketing office



11.21. Flexible height counter

11.5. Taxi

Taxi service is part of the public transport. Here two examples are presented. These cars facilitate the dive-in with wheelchair in which the user can remain during the trip.



11.22. Traditional "London" taxi



11.23. Drive-in from the back.