

## New application of geothermal energy

*Új típusú geotermikus energiahasznosítás*

*Sándor Kovács<sup>1</sup> – Miklós Kozák<sup>2</sup>*

<sup>1</sup>*Energy expert, H-6725 Szeged Gólya utca 7.*

<sup>2</sup>*Department of Mineralogy and Geology, H-4032 Debrecen Egyetem tér 1.*

**Abstract** – It is widely known that in order to reach sustainable development and to avoid environmental disasters the application of renewable energy has to dominate in the energy production network. The authors see the application of geothermal energy as the most perspective one and they present the results of a Hungarian–American joint research and development based on a Hungarian patent.

**Összefoglalás** – Közismert, hogy a jövőben fokozatosan át kell térnünk az alternatív energiák hasznosítására, részben a fosszilis energiahordozók véges volta, részben a fenntartható fejlődés céljából és a környezeti katasztrófák megelőzése érdekében. A szerzők legperspektivikusabbnak a geotermikus energia hasznosítását látják, s e közleményben egy magyar szabadalomra alapozott magyar-amerikai közös kutatás-fejlesztés eredményeinek előzetes bemutatását adják közre.

**Keywords** – energetics, geothermal energy, deep heat mining, Pannonian Basin

**Tárgyszavak** – energetika, geotermális energia, mélyszinti hőbányászat, Pannon-medence

### Introduction, setting the problem

The complex material evolution and differentiation processes together with the fundamental material and energy flow of the Earth are the result of reactions, distribution, global and local (endogenous, exogenous) anomalies of the geothermal heat radiating from the interior and the solar radiation. This means that besides the effects of the gravitational and electromagnetic fields – frequently overprinting them – the evolution of the biotic and abiotic material, the rock cycle, the global changes and extinctions are caused and repeated by the alternatively slow and rapid variations of the geothermodynamic system of the Earth including a series of accidental but drastic disasters and cataclysms (see rapid climatic changes, impacts of extraterrestrial bodies, global tectonic movements, surface dissection, volcanism, earthquakes, systematic and occasional mass movements, material transport, water circulation, hot and cold atmospheric and oceanic currents, heat, water and frost effects, soil formation and degradation, etc.) as well (KOZÁK & MCINTOSH 2007).

The presence of energy in the interior of the Earth was already observed in the antiquity regarding volcanism as the activity of “Hephaistos” endangered populated regions. The heat of the Earth occurs in the description of J.B. Morin a French traveller in the 17<sup>th</sup> century which is the first scientific publication, however, correct observations were carried out only in the 1860s and 1870s with the leadership of Lord Kelvin the famous teacher of the University of Glasgow. According to the first measurements the heat flux value of 55.5mW/m<sup>2</sup> was determined from which the quantity of heat released vertically (radially) through a surface unit from the interior of the Earth into the Space can be estimated. The total heat loss by seconds of the Earth via heat radiation is 3,2x10<sup>13</sup>J calculated on the basis of present heat-flow data.

The intensifying of the environmental crisis together with the global climatic changes and the increasing energy needs gradually turned the attention of the developed world towards the alternative energy sources and environmentally sound energy usages. Many new research and development was triggered in the most developed

countries as there the planner capacity, industrial background and financial potential are present. Hungary belongs to the developed countries of the World considering innovation.

An international group headquartered in the U.S.A. is engaged in the exclusive, worldwide commercialization and development together with an internationally recognized Hungarian university exploring a base-load power generation solution calling it the Advanced Geothermal System™ (AGS). The group recently declared a positive technical and economic feasibility study assessing this groundbreaking energy supply option. Existing systems are hardly comparable to the technical and economic efficiency of the GEPP (Geo-Energy Power Plant). It presents an opportunity for fulfilling the growing worldwide demand for long-term, environmentally responsible and highly competitively priced energy generation compared to nuclear, oil, gas and coal virtually anywhere around the world, where the upper stratum of the earth is suitable for drilling. The computer model developed for the GEPP estimates that the maximum energy content of the system is 8.24GJ by seconds. The electricity output capacity of the Plant using this is 470MW when appropriate geological conditions are present.

Research-driven improvements in geothermal projects are presented in three areas (drilling, power conversion and reservoir technology) and Project GEPP is targeting all three. The use of clean technologies will minimize greenhouse gas emissions and provide a much needed, reliable and low-cost new source of electrical power.

The heat energy source that the GEPP intends to tap into is the geothermal gradient, simply said the heat contained in the Earth’s crust, which increases by 2.62–2.78°F/100ft. or 30–33°C/km on average around the world and 3.17–4.81°F/100ft or 40–70°C/km at some places. The existing geological heat energy resource in greater depth is several times larger than the energy content of geothermal energy and coal. The authors for better understanding use the term geothermal energy as the heat of the Earth exploited through vertical heat transmission only. The solely horizontal heat supply characterised by curved heat-flow pattern produced by the continuous production of heat is called here geological heat energy.

This heat-flow pattern is cylindrical in the case of homogeneous space and can be described by simple functions.

The technology was granted one utility patent (outlined in the present paper) and the improved system offers solutions for the three major challenges for geothermal energy, namely resources are difficult to locate and tend to be found in rural areas and the great issue scientists thought was virtually impossible to overcome: water does not transform into steam at pressures of over 330bar. The technology provides efficient heat insulation in the upper, passive part of the borehole and it harnesses the heat content of the horizontal heat waves moving towards the pipes of the lower, active section of the borehole by converting this energy into electricity – as opposed to other solutions that focus primarily on vertical processes and the heat energy gained from the cooling double phased system. Thus energy is transported by surfacing hot geothermal water. This water can be natural with slow and only partial supply or injected into fractures produced in depths of 2000–5000m. Sometimes this water is cleaned fresh water or sewage. In this way the hot dry rock (HDR) beds deep below the surface operating as heat exchanger with unknown efficiency. The GEPP technology runs on a fixed course and fully adheres to the principal tenets of thermodynamics. It requires no subsurface reservoir, is self-sustaining underground and does not require the use of surface or subsurface water as it is a closed system.

Based on the planned values the GEPP shows attractive economics at Base Case projections with investment cost per net power output capacity resulting \$997.26/kW. GEPP capital cost is est. at \$139M and \$468.6M including power plant installation. Annual levelized electricity and direct heat generation cost is est. at \$75.4M (including Depreciation and Amortization) or 1.91 ¢/kWh. Annual operating and maintenance (O&M) costs excluding financing, D&A, CAPEX and property taxes were calculated to be \$31.8M or 0.81 ¢/kWh and 6.79% of total investment and 20.14% of gross electricity generation revenue. With an EBIT multiple of 6 Base Case (470 MW, \$0.04/kWh price) Pre-Tax IRR is 20.58% over a 10-yr projection and NPV (12.8% WACC) is \$79.3M. Pre-tax IRR is 38% and NPV (14% WACC) is \$336M using a higher energy price of \$0.06/kWh. Electricity generations were calculated as a function of annual full-load operating hours of 8,400 hours.

Existing geothermal technologies in commercial use around the world are steam, binary, hot dry rock (HDR) and Kalina Cycle. Typical capital costs for new geothermal plants range between \$2,900 and \$3,500/kW with annual O&M cost for existing plants of 2 to 2.5 ¢/kWh requiring re-drilling wells every 10 years and re-injecting water into reservoirs. Locating hot geothermal reservoirs are necessary that are usually situated in hard to find rural areas and plants rarely reach 100 MW net output capacities. Existing geothermal plants are well documented publicly around the world and a study published by a Massachusetts Institute of Technology (MIT)-led interdisciplinary panel provides a great insight into the details of current technologies and plans for the future called Enhanced Geothermal Systems (EGS).

The Geothermal Energy Association (Washington, DC) says that the GEA applauded the comprehensive energy legislation planned and prepared by House members. It is expected that this regulation will help put America on the path to energy independence and sustainability. The Department of Energy (DOE) plans provisions authorising an “Advanced Geothermal Research” programme and extending the deadline for renewable energy tax incentives that or similar ones would be highly necessary in Hungary as well.

Professionals say that geothermal power is an important part of the nation’s renewable energy portfolio because it can meet critical base load power needs. Because some renewable energy sources operate only under favourable weather conditions or certain times of the day, critics argue renewable energy will be limited in its ability to meet the looming large-scale power needs of the twenty-first century. Geothermal resources, however, provide reliable electricity on a continuous basis – 24 hours a day, 7 days a week, 365 days a year – with significantly lower emissions levels than fossil fuel sources while avoiding problems of radioactive and other waste disposal.

According to recent reports from the National Renewable Energy Laboratory, the Massachusetts Institute of Technology and GEA, geothermal resources hold the potential to produce hundreds of thousands of megawatts of geothermal power, trillions of cubic feet of gas from geopressured resources, and tens of thousands of quads of heat energy. The United States is the world's largest producer of geothermal electricity, generating an average of 16 billion kilowatt hours of energy per year. Hungary is also among the leading countries (LUND & FREESTON, 2001), in producing geothermal energy (not electric) as its conditions are advantageous.

It has become clear that on the one hand the traditionally applied fossil energy stocks of the Earth are finite and on the other hand, these energy types cannot be used in an environmental friendly way. Therefore the significance of alternative energy types increases gradually. At the moment five alternative energy types look to be profitable, however, their significance and quantity might be different according to regions. In the case of Hungary these energy resources are the followings:

- **geothermal energy** (national)
- nuclear energy (national)
- underground coal gasification (regional and partly national)
- biomass energy (local and partly national)
- solar energy (occasional and local)
- wind energy (dependant on weather and local conditions)

Due to different limitation factors only the first three are suitable to satisfy greater demands. In this paper the geothermal energy is discussed flashing light on its new perspective.

### Geothermal heat-flux specifics regarding the structural development of the Pannonian Basin

The amount of the heat-flow detected near the surface is not equal to the energy stock available for excavation through horizontal and vertical supply in great depth. It is supposed that the horizontal energy movement equalizes under a certain depth.

This seeming controversy can be explained by the distribution of the varying rock strata and their individual characteristics (porosity, moisture content, conductivity). The differences between them are usually reducing with depth and they are partly equalized.

Below the depths of 2000–3000m porosity is significantly decreased and water content capable for circulation is very rare. Water (and other fluids) are present in smaller closed lenses (structural, lithological traps) under pressure due to compaction or migrate towards the near surface strata under less pressure during the diagenetic compaction. The rock system heterogeneous considering mineral and element composition becoming two and then one phased with increasing lithostatic pressure and temperature towards the deeper levels gradually crosses over the zones of anadiagenesis, anchi- and epimetamorphism. Allo- and isochemical metamorphic processes occur in the strata thickening with the increasing of the lithostatic and geodynamic compression within the subsiding or relatively subsiding due to dissection accumulative basins that are under the effect of the global tectonic shortening. With the gradual releasing of

the fluids and the closing and filling of the pores quasi closed (isochemical) metamorphism increasingly appears.

Due to the effect of Earth heat and geodynamic activity together with frictional heat that is capable of significant local increase and excess heat occurring in the environment of local magma intrusions element migration in the solid phase has to be regarded in locally different rate. For example the movement and local enrichment in the inter lattice space of alkalis and other excitable elements that can be easily torn from the crystal lattices. In extreme cases the local heat excess and alkali enrichment reducing the melting point may cause partial crust melting (see specific cases of granitisation) associated with linear belts along the shearing, folding and thrusting structures even in the depth of 4–8km. This process may occur both in the folded orogenic mountains like the Alpine–Carpathian system and in the older multiply reactivating basement containing folded and fractured thrusting and shearing structures and breccia zones of inter-arc inner basins like the basement of the Pannonian Basin enclosed by the Alps, Carpathians and the Dinarids.

Traces of several subsequent orogens (Bajcalian, Cadomian, Caledonian, Hercynian) can be detected in the Pannonian Basin and the Alpine folding is still active today from the late Jurassic. Due to these renewing effects the basement is strongly mosaic and it is orientated into belts with the traces of numerous strike-slip faults (POSZGAY et al. 1996) and up and over thrusts associated with metamorphism of varying grade, local granitisation, synorogenic magmatism at times, partial exhumation and denudation and structural reorientation (Fig. 1).

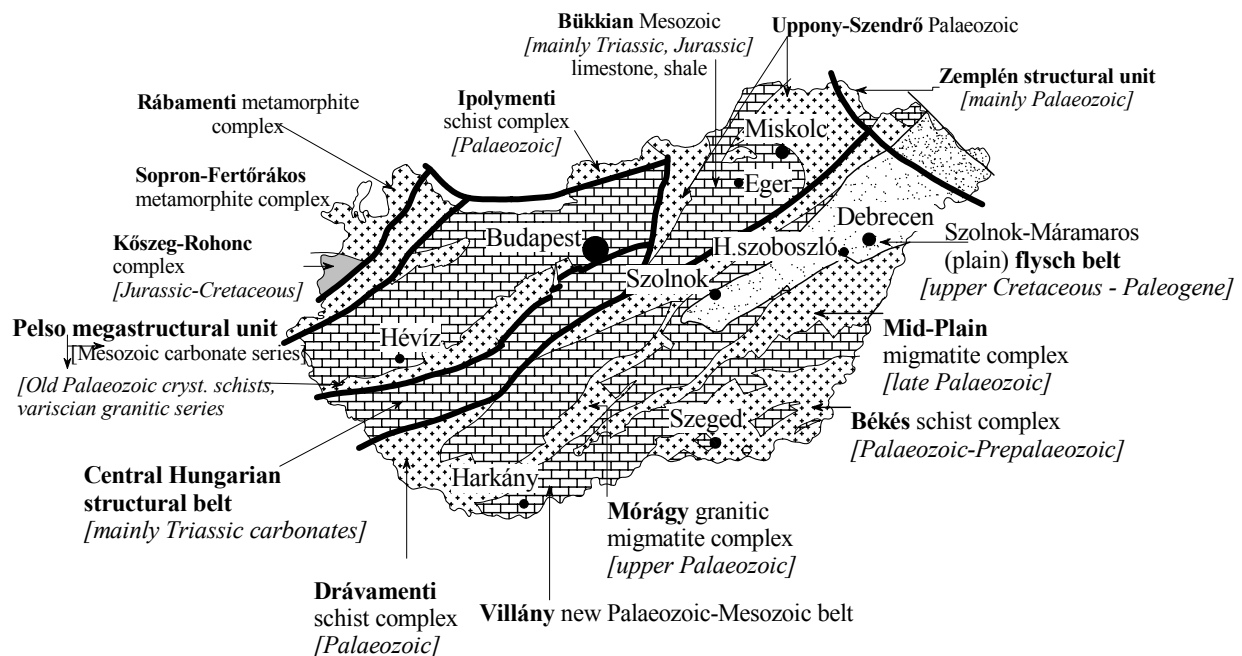

Figure 1 Structure of the Palaeozoic and Mesozoic basement of Hungary without Cenozoic covering sediments  
1. ábra Magyarország paleo-mezozoós aljzatának szerkezete a kainozoós fedőüledékek elhagyásával

The Carpathian orogen forms divergent mountain ranges that verge towards NE, NW and N as well (FODOR & CSONTOS 1998) due to the effect of a geodynamic force

system acting from three directions (MCINTOSH & KOZÁK 2006). These directions are detectable in the elevated mountains and in the basement of the inner basin as well,

however, the dominant orientation is N, NW in the country. Besides, the basement of the interlocked basin is characterised by crustal thinning (25–27km) and strong continentalism with the very limited occurrence of ophiolites. Linear structured Hercynian granitic belts are found along the Balaton line and the Mid-Hungarian Structural Zone with NE–SW strike reaching above the

In the Hungarian section of the deep seismic profiles (Pannonian Geotraverse) produced with international co-operation it can be clearly observed that there are stresses and deformations in the lithospheric mantle as well along the zones of thinning and thrusting and these joint and fault lines reach deep into the material of the lithospheric mantle (POSGAY et al. 1996, 2000).

In the elevated island like fractures of the basement and in the mountain belt uncovered by young volcanics the tectonised and palaeokarstic Triassic carbonate sediment fractures are the relatively most water conductive and water holding formations. These form a hydrodynamic system connecting in the mountain blocks fractured and folded and elevated to the surface. Here, the descending cold karst water and the deep thermal karst of the subsided foreground supply a thermogravitational hydrocirculating system. In the Cenozoic sediments mainly the fluviolacustrine and the lacustrine Upper Pannonian and the Pleistocene fluvial formations contain strata having good water yield. However, from these only the Upper Pannonian water yielding strata subsided into a depth of 500–600 metres can be regarded as thermal water holding strata.

It is directly visible from the above that despite the seeming uniplanarity the structure of the Pannonian Basin is rather variable especially from petrophysical, heat conduction and fluid flow points of view. Apparently, ascending thermal hot springs presented the earliest stage of energy utilisation and these are found along the joints of the edge of the Triassic mountain zones where thermal karst lies in their foreground on the basement of the regions (e.g. thermal line of Buda, Eger, Miskolc-Tapolca). The second source of thermal water were the thermal karstic basements drilled in the vicinity of these hot springs, however, these rarely reach over the temperature of 30–60°C due to the mixing with the waters of the descending karst zone (e.g. Harkány, Széchenyi Bath Budapest, Egerszalók, 20. August Bath Miskolc). The Upper Pannonian thermal groundwaters were mostly exposed by hydrocarbon drillings from the 1930s and by today their number reaches beyond 500. The bathing towns in the Hungarian Plain were developed onto such boreholes (e.g. Karcag, Hajdúszoboszló, Debrecen, Szeged and its vicinity).

Hydrocarbon exploring drillings produced much information on that the increasing of the temperature distribution with depth is linear in the sub-basins of the Plain filled by young sediments due to the hydrological communication of the strata. Thus, base temperatures of 200–250°C and 250–300°C can be expected at depths 4000–5000m and 5000–6000m respectively. The relatively elevated compact granitic parts of the crystalline basement presents even hotter heat domes compared to this. However, their heat content can be excavated only by the Hot Dry Rock technology (TANCZENBERGER 2003).

surface at two points. The Palaeozoic and Mesozoic basement in its present state is strongly fractured, folded and shows 5–6km of surface differences as a maximum with thrust ranges and intermittent trenches orientated into a strike of NE–SW. Its surface depressions are filled by less consolidated dominantly siliceous, clastic marine, lacustrine and fluvial deposits and subordinately carbonate sediments.

The best are those compact granitic, granodioritic or metamorphic (e.g. gneiss) basement blocks that considering deep heat mining above which clayey tuffitic heat and water insulating strata are found.

Although the geoisotherm and heat-flow maps (BOLDIZSÁR 1976, ČERMAK & RYBACH 1979, NÉMETH 2002) counted to different depths were given by several authors on the basis of numerous methods in the last 50 years their differences and slight controversies indicate that this task is very complex and complicated with strongly differing areal and spatial distribution of the datasets.

Heat-flow measurements of Tibor Boldizsár in Hungary in 1943 proved that the vertical heat-flow in the Pannonian Basin is twice the value of the average of the continental crust (BOLDIZSÁR 1976). Through the industrial research of different raw-materials (coal, hydrocarbons) many data on the geothermal characteristics of the geological formations of the country and on the geothermal gradient (m/°C) measurable in certain regions became available.

The values greatly vary (12–40m/°C) due to the local differences in the structural, petrographical and hydraulic conditions of the given areas. The average value if there is any is 18m/°C.

The horizontal equalization of the anomalies can be relatively fast under a certain depth except for the fault and breccia belts of thrust zones.

Due to the rapid horizontal and vertical structural morphogenetic changes and the similarly fast filling of the subsiding basins structural stresses, density and geothermal regional anomalies were left in the system that are relatively slowly equalized. Considering only the last 10 million years the magnitude of the relative surface movement has been around 5km. The rapid subsidence and filling of the basins results in the small amount of embedded organic material. In contrary in the area of the deepest sub-basins the time of crossing the critical temperature zones of the material is so small that the quantity of the fossil water closed in the pores is great and earth gas overtook oil in the geothermal based biogeochemical curing of the kerogen (see e.g. Makó trench, Penészlek, Álmosd).

The thermal water aquifers explored in numerous places resulted in the development of the bathing industrial, balneotherapeutic, and multi staged thermal water usage not counting with the rapid decreasing of the strata energy, scaling and the environmental-ecological effects of the waters containing great amount of dissolved material returned into the natural surface waters.

The deep heat mining established on “Hot Dry Rock” is much more perspective; the experimental operations of which carried out in certain countries (USA, France, Switzerland, New Zealand) are promising, however, by this method only limited amount of electricity can be produced in environment friendly way (VUATAZ & HAERING 2001).

### Excavating the heat of the Earth

The first utilisation of the heat of the Earth was the use of the water of the hot springs (e.g. Iceland, USA, Italy, Japan). Geysers as natural thermal water springs are also natural outflow of geothermal energy. Thermal water fields recognised by geological research usually came to know in areas of active volcanism having great heat outflow (hiperthermal areas) and in basins storing thermal water. There are numerous examples on the excavation of their heat by deep boreholes (KORIM 1978, 1990, 1991) even in the first part of the 20<sup>th</sup> century (Larderello, New Zealand, Iceland, etc) and there are numerous positive examples in Hungary as well. For a long time geothermal energy was associated to subsurface hydrogeological waters and this causes misunderstanding even today as appliers and laymen associate the excavation of the heat of the Earth exclusively to the thermal waters stored in the upper part of the crust.

Already in 1995 the heat power plants produced 5600MW of geothermal energy in the World, however, several times more geothermal energy is used in different ways. In certain countries electric energy obtained from the heat-flow had significant rates previous the turn of the millennium.

In many countries communal and smaller industrial warm water is produced with the help of horizontal and vertical heat-probe (5–250m), heat-pump and circulating heat transmitter. Its significance is found in the possibility of producing environment friendly heat energy and not exclusively in energy saving.

Today, mostly the thermal water of the hiperthermal areas with great enthalpy (>150°C) fields are used to operate turbines for producing electricity worldwide.

Although Hungary is considered an area of small and moderate enthalpy the possibility is present, however, in limited amount to utilise the thermal waters gained from the Upper Pannonian strata of structure and hydrocarbon exploring drillings drilled on the elevations, heat domes of the basement for electric energy (TANCZENBERGER 2003). Unfortunately, this is not economic in the case of the already drilled boreholes (e.g. the vicinity of Álmosd and Kokad) with depths of 2000–3000m.

There are domestic examples as well for the economic excavation of heat energy used for heating by heat-exchangers and circulating in a closed system ammonia or other heat sensitive fluids with low boiling temperature (TÖRÖK 1999, BARABÁS 2003, KOZÁK 2002, 2003, KOZÁK & MIKÓ 2004).

Today, in numerous countries energy is gained by excavating the heat of dry rocks in greater depth. The Hot Dry Rock experimental system is operated in the National Laboratory of the USA in Los Alamos and in the Soultz Project (NÉMETH 2002). This energy obtaining technology may yield several times more energy than the thermal water or the heat-probe methods and in the same time it endangers neither the quantity nor the quality of the surface or subsurface waters. It has no harmful effect neither on the pressure on the subsurface waters nor on the heat content of the waste water. However, the technology raises questions considering its salt content and small power. For comparison a few North American geothermal power plants are described that aim to produce electricity. It is visible that investment costs are relatively high regarding capacity.

Place of establishment	Year	Electricity capacity [MW]	Technology	Specific investment cost [\$/kW]
Blundell	1984	11	flash plant	3000
Desert Peak	1985	9	double flash plant	2000
Beowawe	1985	16	double flash plant	1900
Heber	1985	47	double flash plant	2340
Steamboat Hills	1988	12	double flash plant	2500
Empire	1987	3	binary	2700
Dixie Valley	1988	66	double flash plant	2100
Stillwater	1989	12	binary	3085
Brody HotSprings	1992	24	double flash plant	2700
SIGC	1993	33	binary	3030

Table 1 Cost and capacity of a few traditional geothermal power plants in the USA

1. táblázat Néhány az Egyesült Államokban működő hagyományos geotermikus erőmű költsége és teljesítménye

### Hungarian patent for excavating heat from great depth

Horizontal heat supply increases with greater depth compared to the near surface zone due to the even heat distribution, thus the heat produced from here may be several times more than the energy from thermal water. According to certain calculations, the energy that can be recovered from deep heat movements in Hungary could

even be several hundred TWh Crust structural and geological conditions of excavation are variable according to regions but if the number of potential excavation sites of heat energy from great depth calculated as an average for the area of the country is reduced to the optimal number then still the amount of energy is potentially available that would fulfil the majority of the domestic heat demand. Surface space requirements of the new excavation are low,

supply is continuous and energy is obtained without natural transmitting media i.e. with environment friendly methods.

The above gives the base for the patent of the author Sándor Kovács that is aimed to excavate and utilise the thermal energy store with square heat supply of the geological formations in great depth. The technique described in the patent enables the production of an economic energy independent from other energy resources and free from releasing any material loading the environment.

This system is completely closed therefore it has no effect on hydrocarbon exposition and excavation potentially established in similar great depth (4000–6000m). Thermal water wells of moderate depth (500–2200m) and the drinking water wells of smaller depth (50–450m) are neither disturbed.

To implement the technology outlined here in Hungary, drillings around 6000m deep are required depending on the geological conditions. Calculations were carried out on this depth level. The deepest boreholes in the World (e.g. Oklahoma 9500m, Kola peninsula 12000m) reach beyond this depth by several thousand metres (KOZÁK & MCINTOSH 2007) and the technology is owned by several research borehole companies throughout the World. Even in Hungary several boreholes having a depth between 4000–6000m are drilled.

In our case the technology used at oil drilling can drill 2 pieces of standpipes into 6000 metres. For reducing the required space the surface distance of the two boreholes is only 50m, however, this distance is 576m between the bottom points due to the tilting of one of the boreholes. This is beneficial regarding disadvantageous interaction and the cooling of the environment can be minimalised in the

depth of the heat excavation and the surface space requirement reduces so much that there is only a very limited energy loss during the movement of the material between the two wells (KOZÁK & KOVÁCS 2006).

To operate the system, distilled water is required impeding scaling. Pumps prepared for this aim enable the circulation of the distilled water in the upright steel drill pipes. Reaching the appropriate depth so called dry steam with a temperature of 270–280°C is obtained which is recycled in the inner “producing pipe” with large diameter and it is directly driven onto the paddles of the steam generator.

According to the calculations of the patent founder, taking the velocity of the water in the boreholes as 10m/s, 1200m<sup>3</sup> of water is running through the system per hour. Calculating with 1200m<sup>3</sup> of circulating distilled water in the case of 1200t of steam with temperatures of 260–280°C (average 270°C) the produced energy has an output of 8.24GJs. According to the computer simulation, the produced steam has a pressure of 120 bars and a velocity of 27m/s. In the last phase, the temperature of the steam can be increased from 260°C to about 350°C by applying a special technique. With these parameters and energy content, around 500MW electric energy can be obtained from a system with the even heat supply of the assumed homogeneous area. The outer key-factor of implementation is the geological conditions.

In the first stage electric energy is produced and the remaining energy of the cooled steam can also be utilised in a generator in the second stage or for heat supply through heat converters.

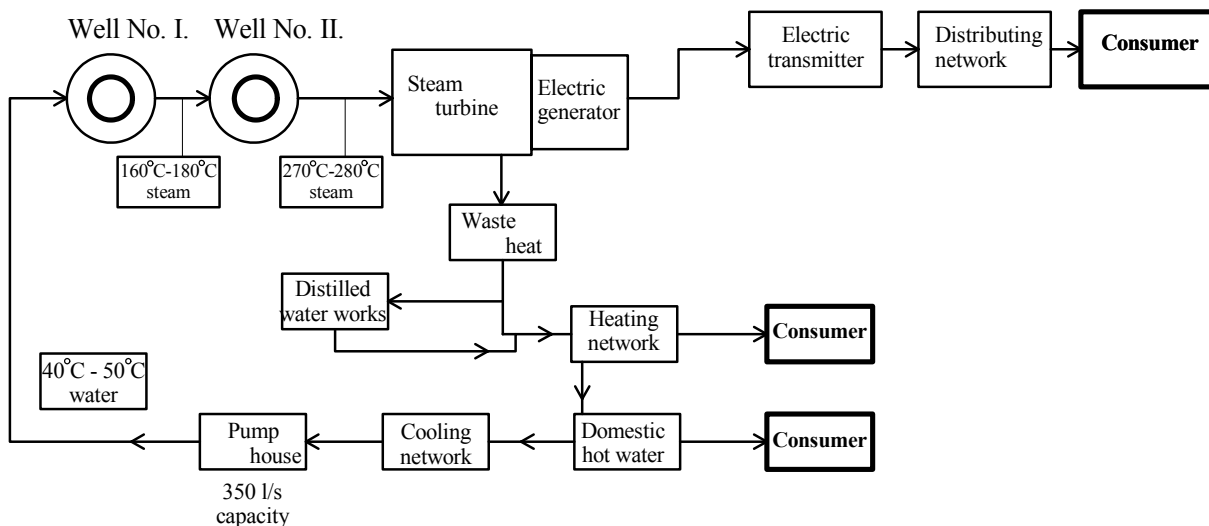

Figure 2 System model of the twin deep drilled geothermal heat utilising energy system  
 2. ábra Mély ikerkutas geotermikus hőhasznosító rendszer rendszermodellje

The operation of the system requires energy only in the case of triggering the starting impulses. After this the system is self sustaining, can be controlled by computers

and it can be operated periodically or continuously. The distilled water cooled in the course of the operation can be

recycled into the system and the slight loss can be recovered from the distilled water built in the system.

The practical significance of the patent can be best understood if the national energy production and utilisation trends are analysed. In 1960 74% of the Hungarian energy demand was supplied by coal and coal productions (coke, briquette) while 12% was given by hydrocarbons. By the turn of the millennium this rate was modified and turned. In 2002 the share of the coals was 12.3% while that of the hydrocarbons was 70.1%. The rate of the nuclear power plant in Paks was 11.9% in the total energy usage of the country.

The energy structure was changed fundamentally in Hungary in the last four decades with a significant increase of the rate of the imported energy. Electricity consumption was significantly reduced following the regime change in 1990. In 1994 with a value of 127PJ (35.2TWh) it was only 87% of the greatest production in 1987. The total energy usage was 1038PJ in 1994 and that is only 77% of the greatest usage in 1987. The role of the nuclear power plant in electricity production was increased (~40%) in this changing structure.

In 1993 the Hungarian Parliament accepted the new concept of energy policy formed by the Ministry of Industry. Its essence is the following

- preserving energy safety, reducing one sided import dependence, diverse import, collecting appropriate strategy stores;
- intensifying energy saving, increasing its efficiency and thus increasing the competitiveness of the economy;
- establishing the agency, economic and legal framework of a market based energy policy;
- exercising environment protectional relations, drawing in publicity
- intensifying European integration.

Unfortunately, the above were not applied efficiently. The best example for this is the limited increase of applying renewable energy resources due to the immaturity of inciting actions (e.g. consultation, legal control, tax compensation, supports). Therefore in 2002 the electricity production originating from renewable energy was only 318.38GWh (0.8% of the national production) including no electricity production from geothermal energy. The total heat utilisation was somewhat better with a value of 35,182TJ (3.3% of the national heat utilisation) from which thermal water shared 3,600TJ while heat excavation by heat pumps produced 40TJ. The latter started a progressive increase, however, it is far from the planned value.

### Capacity and cost of the new geothermal power plant

The operation of the new deep drilled system of Sándor Kovács's patent requires distilled water primarily to avoid the development of scale. With the help of the technology that utilises the natural pressure state of the distilled water driven into great depth by pumps, so called "wet steam" with temperatures between 160°C and 180°C is produced in the first borehole. This is driven through the second borehole producing steam with a temperature of 260–270°C holding the energy of 8.24GJ per second. The

steam temperature requirement of the present steam turbines is 350°C or higher as an optimum. Therefore to increase efficiency an additional technique has been developed that increases the temperature of the steam up to 350°C without applying any fossil energy only a slight recycling of its own production.

The establishment of a geothermal system of a single twin borehole assures the production of 1200t/h of steam. This would produce electric energy with 500MW output in calculating with efficiency of 30%. Accurate steam-flow and output values can be determined in the course of the trial operation. The electric energy produced in a single geothermal unit may give 30–40% of the output of the nuclear power plant in Paks. Apart from the electric output the system may produce further heat energy that would be enough to fulfil the energy demand of smaller town.

The cost of energy production falls way below the cost of the power plant in Paks which is considered to be economically sound. The cost of the investment is 900–1200\$ for 1kW electric power which is the half or third of the investment cost (2000–3100\$/kW) regarding the present economic conditions.

The geothermal system described in the patent can be established in many geotectonic environments in numerous points of the crust which are relatively safe considering earthquakes, however, according to the estimations, the system safely endures earthquakes with magnitudes 4–5 if they are not accompanied by faults of several dm or m. The system causes no harm to the environment even if damaged. It is apparent that regional and local geological conditions may influence the operation, efficiency and output of the system significantly.

Comparing the potential of some North American geothermal power plants given in *Table 1* it is clear that the recommended technology requires very slight specific investment cost regarding its potential. Considering the present costs the establishment of this new system is only 40–60% of the first cost of the units of the traditional energy production types and its return period is 1–1.5 years in the case of optimum conditions. However, the cost of the single investment is relatively high.

The implementation requires special techniques but it can be established in numerous places even at sites where no energy production was possible whatsoever.

### Environmental aspects

This technology *does not damage those natural values* that are listed by the Hungarian and European Union Act LIII of 1996.

The system is closed into itself and makes no harm to the quality of the air at all and causes no air pollution thus it fulfils the prescriptions of the MT Decree 23/1986 (VI.2) on the protection of the clean air. Geothermal energy production produces no air pollutants (sulphur dioxide, carbon monoxide, hydrocarbons, photochemical oxidants, granular pollution) ruled in the EU and the USA and frequently associated to the operation of other power plants.

According to the decree 12/1983 (V.12) this technology produces no noise or vibration.

No surface water is required for the technology and it releases no sewage therefore the Hungarian and EU decree LVII. of 1996 would not apply to that.

The prescriptions of the government decree 33/2000 (III.17.) does not apply to the subsurface operations described in the decree 3/1984 (II.07.) as its operation has no effect on subsurface waters.

The realisation of the technology makes no waste therefore the government decree 102/1996 does not apply to it. Only the staff of the power plant produces communal waste and that can be deposited at depositories marked by the local agencies.

The drilling phase of the technique has to be in accordance with the prescriptions related to oil and gas research to realise the protection of the soil and geological formations.

The closed system of the presented technology completely excludes even the slightest disturbance of the oil and gas research contrary to thermal water production.

### Acknowledgement

The authors thank Richard William McIntosh and Tamás Buday for their useful comments and the translation of the text and The NKGroup for their versatile help.

### References

- BARABÁS I. 2003: „Dry” geothermal well in the Széchenyi building estate in Szolnok (Szolnoki „száraz” geotermikus kút a Széchenyi lakótelepen). manuscript
- BERTANI, R. 2005: World geothermal power generation in the period 2001-2005. *Geothermics* 34, 651-690
- BOLDIZSÁR T. 1976: Applying geothermal energy (A geotermikus energia hasznosítása). Technical Press (Műszaki Kiadó), Budapest, 191 p.
- ČERMAK, V., RYBACH, L.(ed) 1979: Terrestrial heat flow in Europe. Springer Verlag, 328 p.
- FODOR L. & CSONTOS L. 1998: Structural geological studies in Hungary and their newest results (Magyarországi szerkezetföldtani kutatások és ezek legújabb eredményei). *Bulletin of the Hungarian Geological Society* 128/1, 123-143
- KORIM K. 1978: Thermal water wells of Hungary III. (Magyarország hévízkútjai III). VITUKI
- KORIM K. 1990: Development and perspective of applying low enthalpy geothermal energy (A kis entalpiájú geotermikus energia hasznosításának fejlődése és perspektívája). *Oil and Gas* 23, No. 7, 208-212
- KORIM K. 1991: History of the three decades of operation and production of the thermal water field in Szentés (A szentesi hévízmező feltárásának és termelésének három évtizedes története). *Oil and Gas* 24, No. 6, 179-184
- KOZÁK M. 2002: Significance of the heat of the Earth and the possibilities of its excavation in Eastern Hungary (A földi hő jelentősége és kinyerésének Kelet-Magyarországi lehetőségei). manuscript presented in the Conference on Alternative energy of the Association of Technical Scientific Societies (MTESZ) in Debrecenben, 16 p.
- KOZÁK M. 2003: Experiences of the geothermal energy utilisation in the Trans Tisza Region (A (Tiszántúli) régió geotermikus energiafelhasználásának tapasztalatai). ENERGXpo International Exhibition and Conference for Energy 165-167
- KOZÁK M., MIKÓ L. 2004: Possibilities of utilising geothermal energy in Eastern Hungary (Geotermikus potenciál hasznosításának lehetőségei Kelet-Magyarországon). In: KIRCSI A., BAROS Z. (ed.) Researching and Utilising Renewable Energy in the North Hungarian Plain Region (A Megújuló Energiák Kutatása és Hasznosítása az Észak-Alföldi Régióban). Hungarian Wind Energy Association publication No. 2, 11-19
- KOZÁK M., KOVÁCS S. 2006: Geothermal heat sources in great depth (A nagymélységű geotermikus hőforrások). IV. ENERGOexpo International Exhibition and Conference for Energy 122-126
- KOZÁK M., MCINTOSH R.W. 2007: Theoretical significance of geotectonic modelling of the Earth on the basis of geothermics (A geotermikai alapú geotektonikus földmodellezés ismeretelméleti jelentősége). In SÜLI-ZAKAR I. (ed): 56 papers for the 70. birthday of Dr. Gábor Korompai (56 tanulmány Dr. Korompai Gábor 70. születésnapjára). Kossuth University Press, Debrecen 199-207
- LUND, J.W. & FREESTON, D.H. 2001: „World-wide Direct Uses of Geothermal Energy 2000”. *Geothermics* 30/1, 29-68
- MCINTOSH R.W., KOZÁK M. 2006: Experiences of tectonic survey in the Bükk Mountains (Tektonikai felvételezés tapasztalatai a Bükk-hegységben). Mining, Smelting, Geology Conference publication EMT Sepsiszentgyörgy, 262-267
- NÉMETH G. 2002: Opportunities of deep heat mining in Hungary (A mélység-hő-bányászat lehetőségei Magyarországon). *Oil and Gas* 135/7-8, 86-90
- POSGAY, K., TAKÁCS, E., SZALAY, I., BODAKY, T., HEGEDŰS, E., JÁNVÁRINÉ, K.I., TIMÁR, Z., VARGA, G., BÉRCZY, I., SZALAY, Á., NAGY, Z., PÁPA, A., HAJNAL, Z., REIKOFF, B., MUELLER, St., ANSORGE, J., DEJACO, R., ASUDEH, I. 1996: International deep reflection survey along the Hungarian Geotraverse. *Geophysical Transactions* 40, 1-2 1-44
- POSGAY, K., NAGYMAROSY, A., PÁPA, A., HEGEDŰS, E., LÓRINCZ, D.K. 2000: Deep structure of the Szolnok Flysch Belt. *Geophysical Transactions* 43, 2, 71-91
- TANCZENBERGER S. 2003: Érmellék Geothermal Power Plant (Érmelléki Geotermikus Erőmű). manuscript 66 p.
- TÖRÖK J. 1999: Thermal water management in the Great Hungarian Plain (Hévízgazdálkodás az Alföldön). manuscript, TIVIZIG
- VUATAZ, F.D., HAERING, M. 2001: The Swiss Deep Heat Mining (DHM) project: drilling of the first exploration borehole in Basel. IGA News 45, 9-12