



Manufacturing of the surfaces of spline fitting connection

Sándor Bodzás¹

Received: 27 May 2020 / Accepted: 28 September 2020
© The Author(s) 2020

Abstract

The aim of this publication is the analysis of the geometric establishment and the manufacturing designing and development of spline fitting promoting the engineer's designing works. There are many connection possibilities according to the utilization on different constructions. Based on them, different technologies are needed for the manufacturing of the spline shaft and the spline hole. Generally, milling and grinding technologies are needed. These technologies will be analysed. We design mathematical models for the analysis of the milling technologies by mathematical way. We define the technological parameters and the computed machine time for the manufacturing designing process and recommend technologies for the different shapes.

Keywords Spline fitting · Milling · Grinding · Spline hole · Spline shaft

1 Introduction

The application of key joints does not give solution in case of high-loaded parts and moment transmission. Firstly, the engineers try to use two keys by 180° arrangement to solve the load and moment problem. If it is not successful, the application of spline fitting is needed. The spline shaft is connected to the spline hole which has grooves. They are element pair together [1–3]. There are many splines around the perimeter of the shaft with which the high load could be distributed equally (Fig. 1) on the connecting surfaces. The number of splines around the shaft perimeter could be $z = 3, 4, 6,$ and 8 . Three types of the spline fitting are standardized [1]:

- Square spline fitting
- Triangular spline fitting
- Involute spline joint

If we have to provide axial motion for a toothed gear on a shaft, the solution of spline fitting could be applicable (Fig. 2)

(<https://tudasbazis.sulinet.hu/hu/szakkepzes/gepeszet/gepeszeti-szakismeretek-1/a-bordastengely-kotes/bordastengely-kotesek-kulonbozo-tipusai>).

In case of the geometric designing, the side surfaces have to be designed for surface pressure (Fig. 3) [3]:

$$p = \frac{F_{per}}{A \cdot \Psi_i} = \frac{M}{r_k \cdot a \cdot l \cdot z \cdot \Psi_i} \leq p_{allowed} \quad (1)$$

The position accuracy and quality of spline fitting are determined by [1]:

- The concentricity and size accuracy of the centralized diameters
- The side sizes of the spline width, division accuracy and the parallelism of the side surfaces in comparison with the centre line
- The surface roughness and hardness
- The accuracies of the fits

The geometric sizes and tolerances of the shaft and the hole are standardized (DIN 5463, DIN 5480).

This work can help for the manufacturing engineers and the technologist for the manufacturing designing of spline fittings. These are the main conventional manufacturing methods that will be analysed. These technologies could be applicable on conventional machines or CNC machines. The mathematical analysis could help for the CNC technological designing and

✉ Sándor Bodzás
bodzassandor@eng.unideb.hu

¹ Department of Mechanical Engineering, University of Debrecen, Ótemető str. 2-4., Debrecen 4031, Hungary

Fig. 1 The geometric establishment of the spline shaft and the spline hole (<https://www.banki-sos.hu/bordastengely-bordastengelyek-bordas-tengely/bordastengelyek-bordastengely-bordas-tengely-197>; <https://hu.depositphotos.com/29381291/stock-photo-splined-connection-on-shaft-isolated.html>; https://regi.tankonyvtar.hu/hu/tartalom/tamop425/2011_0001_521_Geptan/ch02s05.html)

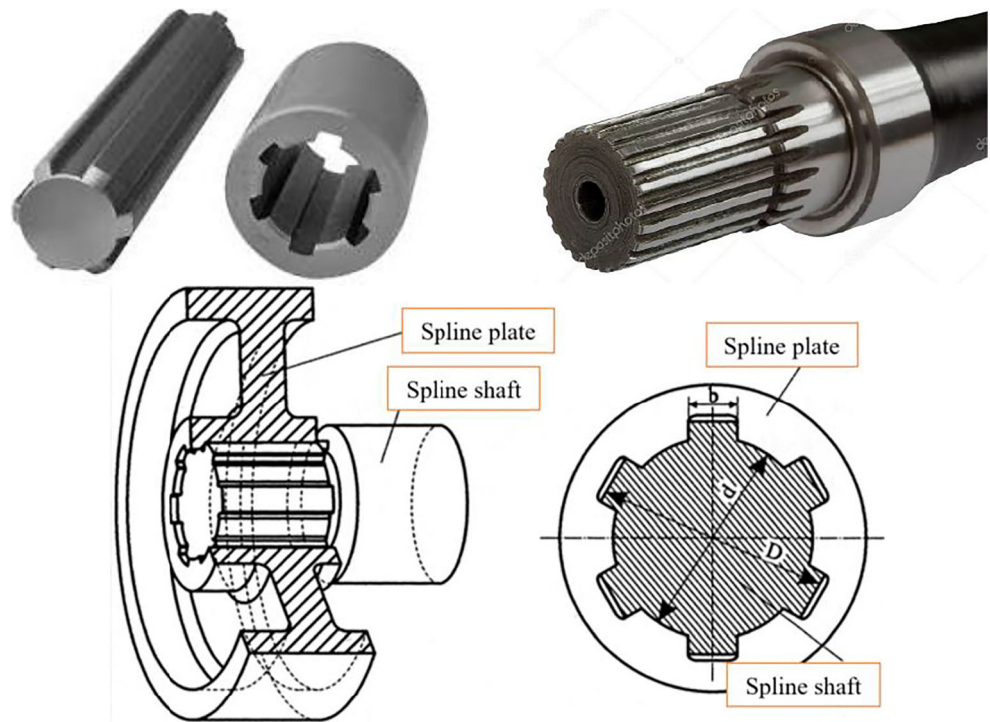

the inspection of the quality assurance by 3D measuring machine.

The flowchart of the design and manufacturing process could be seen on Fig. 4.

2 The centralization possibilities

According to the centralized surface, the spline fitting could be (Fig. 5) [1, 2]:

- Minor diameter fit
- Major diameter fit
- Side-bearing fit

Comparison of the centralizations of spline fitting (Fig. 5) [1, 2]:

1. Minor diameter fit (d_f): the connection happened on the root circle diameter of the spline shaft.

Advantageous:

- The manufacturing of the tip circle diameter of the spline hole (D_a) is simple.
- The concentricity of the root circle diameter of spline shaft could be provided by grinding technology.
- The shaft and the hole could be hardened.

Disadvantageous:

Fig. 2 Movable tooth gear assembly on the spline shaft (<https://tudasbazis.sulinet.hu/hu/szakkepzes/gepeszet/gepeszeti-szakismeretek-1/a-bordastengely-kotesek/bordastengely-kotesek-kulonbozo-tipusai>)

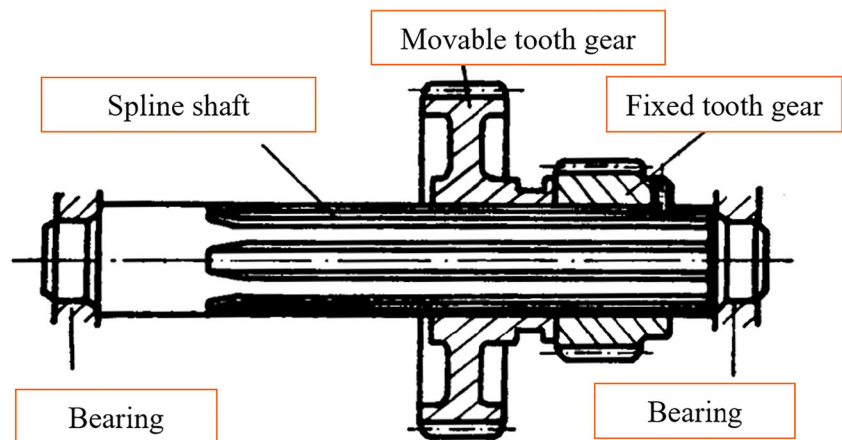

Fig. 3 The distribution of the surface pressure on the spline surface

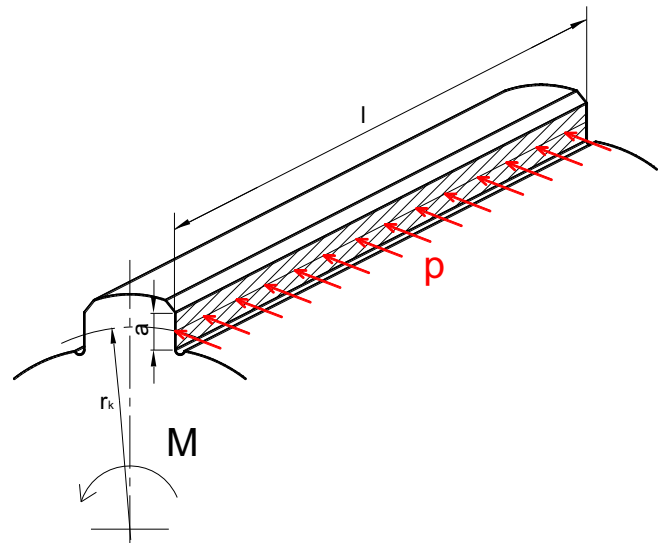

Fig. 4 The flowchart of the design and manufacturing process

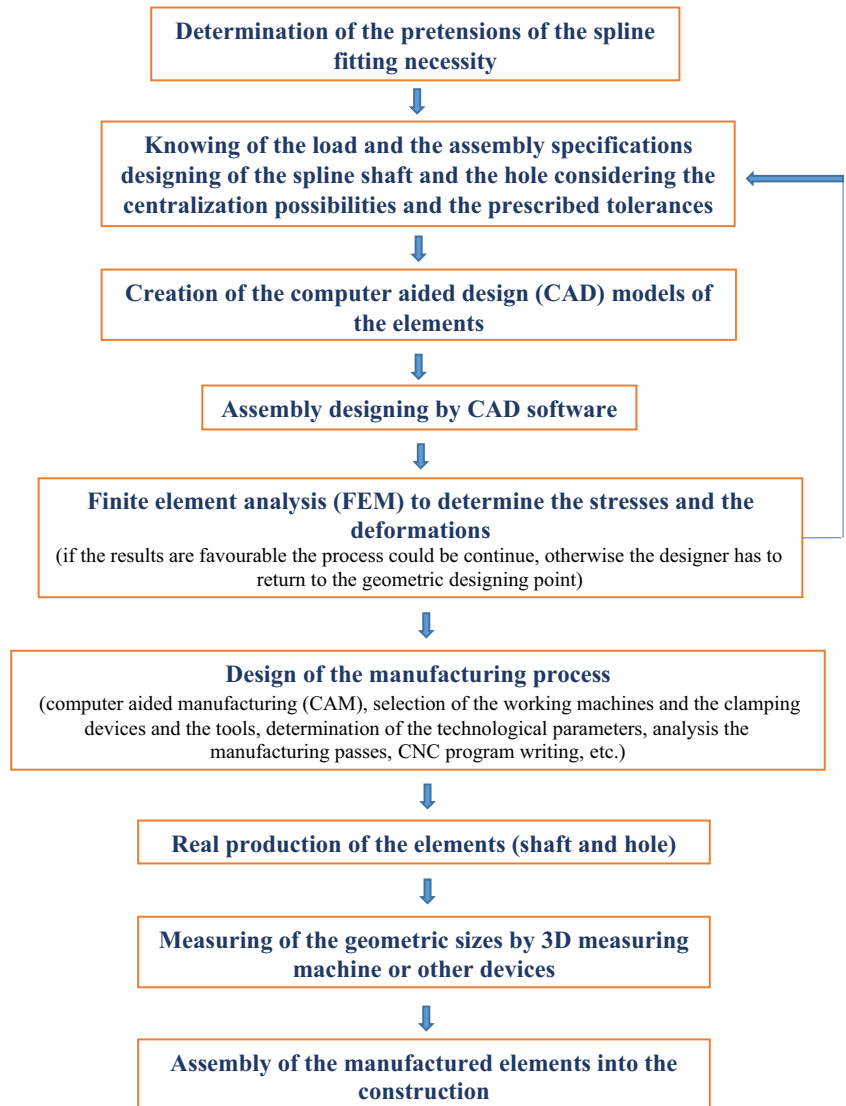
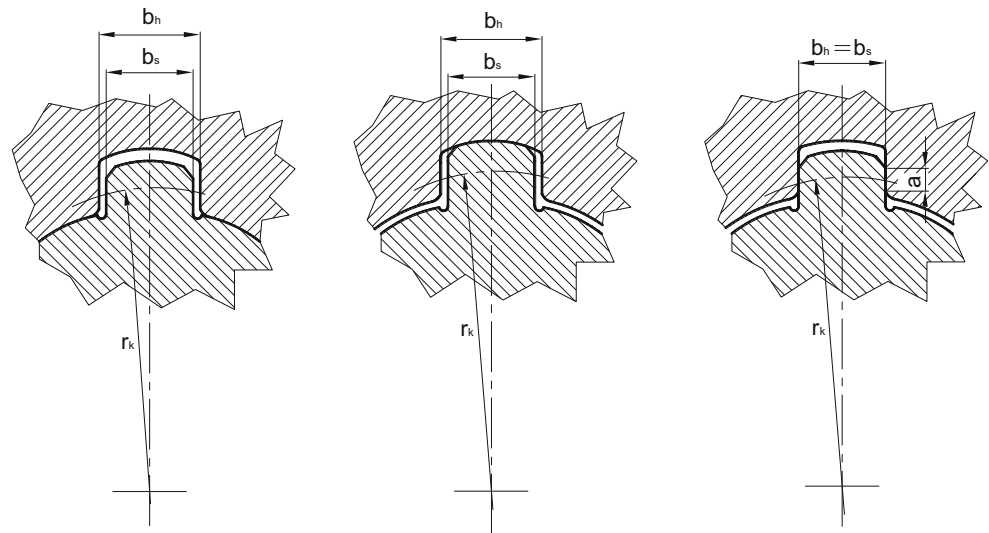

Fig. 5 Different centralized spline fittings: **(a)** minor diameter fit, **(b)** major diameter fit, **(c)** side-bearing fit and **(d)** the sizes of the spline shaft and the spline hole



a) minor diameter fit

b) major diameter fit

c) side bearing fit

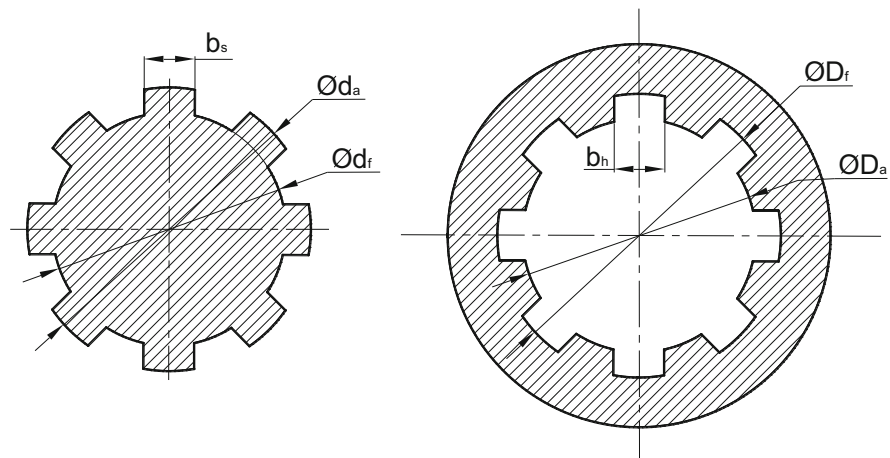

d) the sizes of the spline shaft and the spline hole

- The grinding process of the root circle diameter of the spline shaft (d_f) is difficult and complex.
2. Major diameter fit (d_a): the connection happened on the tip circle diameter of the spline shaft.

Advantageous:

- The manufacturing of the tip circle diameter of the spline shaft (d_a) is easier than in case of minor diameter fit.
- The special working machines are unnecessary for the grinding of the root circle diameter (d_f).

Disadvantageous:

- The hole could not be hardened.

- Calibration heat treatment is indispensable after the normal heat treatment.
- Differences could be received from the concentricity in case of calibration pull broaching.
- Manufacturing of the root circle diameter of the spline hole (D_f) is difficult.

3. Side-bearing (a) fit: the connection happened on the side surfaces of the elements.

Advantageous:

- The most accurate centralization.
- The shaft and the hole could be hardened.

Disadvantageous:

- Manufacturing of the side surface of the hole and the shaft is labour-intensive.

3 Analysis of the manufacturing technologies

3.1 Milling technologies for the spline shaft

After the basic body is created, the following step is the spline milling. There are some possibilities for it. Starting from a conventional horizontal knee-type milling machine, the basic body has to be fixed between centres. The proportional division between the splines is provided by dividing head (Fig. 6) [4–7] (<https://tudasbazis.sulinet.hu/hu/szakkepzes/gepeszet/gepeszeti-szakismeretek-3/alakos-feluletek-marasanak-bemutatasa/fogaskerekek-marasi-technologiaja>).

Based on Figs. 6 and 7, the disc-type milling cutter can manufacture one spline groove. After it is ready, the tool moves from the manufacturing zone. The division between the teeth could be done by the dividing head considering the division ratio in the function of the number of splines. Finally, the milling process can start again. This process has to be repeated in the function of the splines around the perimeter.

The transformation matrix between the tool and the spline shaft is:

$$M_{2R,1R} = \begin{bmatrix} -\cos\varphi_1 \cdot \cos\varphi_2 & \cos\varphi_1 \cdot \sin\varphi_2 & -\sin\varphi_1 & t \cdot \cos\varphi_1 - v_f \cdot \sin\varphi_1 \\ -\sin\varphi_1 \cdot \cos\varphi_2 & \sin\varphi_1 \cdot \sin\varphi_2 & \cos\varphi_1 & t \cdot \sin\varphi_1 + v_f \cdot \cos\varphi_1 \\ \sin\varphi_1 & \cos\varphi_2 & 0 & 0 \\ 0 & 0 & 0 & 1 \end{bmatrix} \quad (2)$$

The two parametric vector-scalar function of the cutting edge is:

$$\vec{r}_{1R} = \begin{bmatrix} x_{1R}(\eta, \vartheta) \\ y_{1R}(\eta, \vartheta) \\ z_{1R}(\eta, \vartheta) \\ 1 \end{bmatrix} \quad (3)$$

The normal vector on the connecting surfaces is:

$$\vec{n}_{1R} = \frac{\partial \vec{r}_{1R}}{\partial \eta} \times \frac{\partial \vec{r}_{1R}}{\partial \vartheta} = \begin{vmatrix} \vec{i} & \vec{j} & \vec{k} \\ \frac{\partial x_{1R}}{\partial \eta} & \frac{\partial y_{1R}}{\partial \eta} & \frac{\partial z_{1R}}{\partial \eta} \\ \frac{\partial x_{1R}}{\partial \vartheta} & \frac{\partial y_{1R}}{\partial \vartheta} & \frac{\partial z_{1R}}{\partial \vartheta} \end{vmatrix} \quad (4)$$

The relative velocity between the connecting surfaces is:

$$\vec{v}_{1R} = M_{1R,2R} \cdot \frac{d}{dt}(M_{2R,1R}) \cdot \vec{r}_{1R} \quad (5)$$

The Connection I statement is:

$$\vec{n}_{1R} \cdot \vec{v}_{1R} = 0 \quad (6)$$

Fig. 6 Manufacturing of the spline grooves of a spline shaft by plain milling technology (<https://tudasbazis.sulinet.hu/hu/szakkepzes/gepeszet/gepeszeti-szakismeretek-3/alakos-feluletek-marasanak-bemutatasa/fogaskerekek-marasi-technologiaja>)

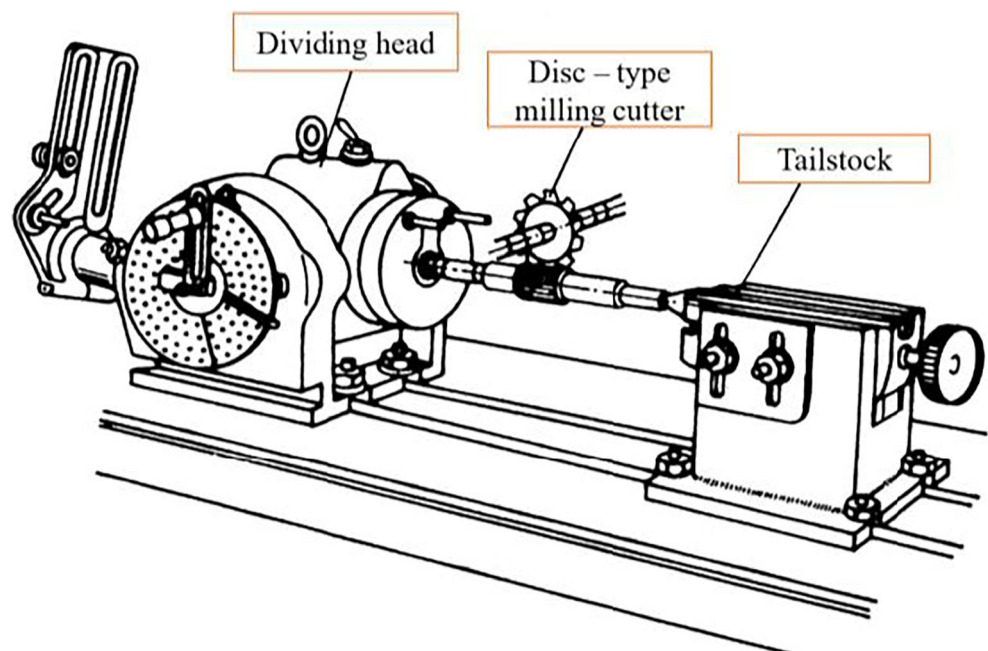
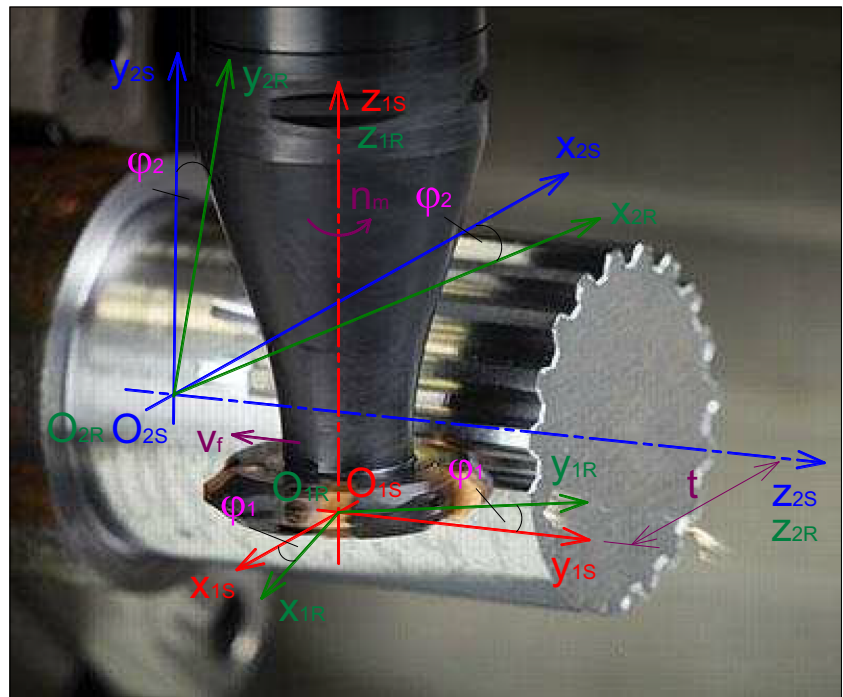

Fig. 7 Coordinate system for the technological analysis



The contact points between the tool and the spline shaft could be calculated by Eqs. (2), (3), (4), (5) and (6) [8].

The t depth is:

$$t = \frac{D}{2} + \frac{d_f}{2} \tag{7}$$

The following initial parameters have to be known for the technological designing: $h, z, l, b_s, d_a, d_f, n$ and f_z .

The w_1 groove width on the tip circle diameter of the spline shaft is (Fig. 8):

$$\frac{d_a \cdot \pi - b_s \cdot z}{z} = w_1 \tag{8}$$

The w_2 groove width on the root circle diameter of the spline shaft is (Fig. 8):

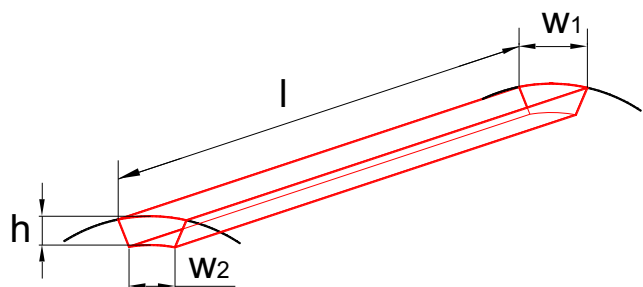

Fig. 8 The geometric sizes of one spline groove on the shaft

$$\frac{d_f \cdot \pi - b_s \cdot z}{z} = w_2 \tag{9}$$

The a depth of cut is equal with the h spline depth. Knowing of the D outside diameter of the milling cutter, the cutting speed is:

$$v_c = D \cdot \pi \cdot n_m \tag{10}$$

The feed speed is:

$$v_f = f_z \cdot z_t \cdot n_m \tag{11}$$

The arc of contact between the milling cutter and the work-piece during the chip separation process is (Fig. 9):

$$i = \sqrt{h \cdot D} \tag{12}$$

The switching number is the number of working teeth of the milling cutter along the i arc of contact:

$$\Psi = \frac{i}{t_p} = \frac{\sqrt{h \cdot D}}{\frac{D \cdot \pi}{z}} = \frac{z}{\pi} \cdot \sqrt{\frac{h}{D}} \tag{13}$$

where the t_p tooth pitch

$$t_p = \frac{D \cdot \pi}{z} \tag{14}$$

Fig. 9 The technological process of the spline milling by disc-type milling cutter

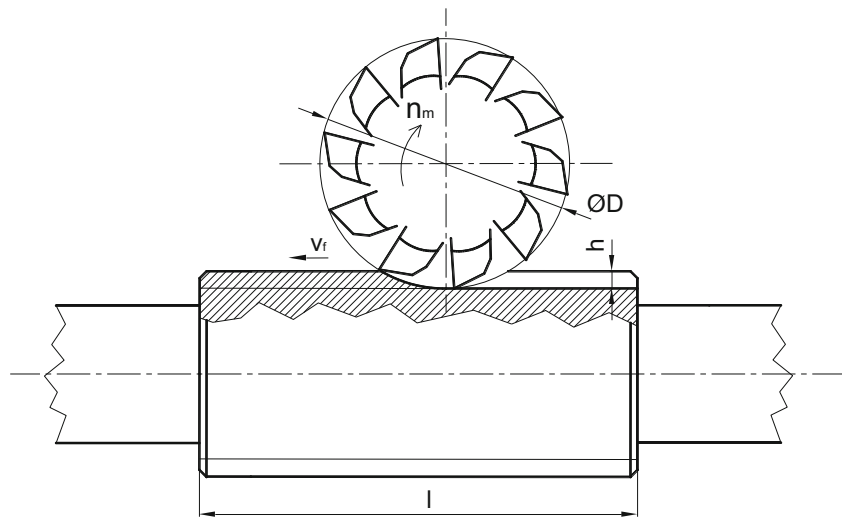

The cutting force for one cutting edge is:

$$F_{c1} = k_c \cdot \bar{h} \cdot w_1 \tag{15}$$

Medium chip thickness:

$$\bar{h} = f_z \cdot \sqrt{\frac{h}{D}} \tag{16}$$

Based on (13), (15) and (16), the total cutting force is:

$$F_c = \psi \cdot F_{c1} = \frac{z}{\pi} \cdot f_z \cdot \frac{h}{D} \cdot k_c \cdot w_1 \tag{17}$$

The cutting power is:

$$P_c = F_c \cdot v_c \tag{18}$$

Considering the efficiency, the motor power of the working machine is:

$$P_m = \frac{P_c}{\eta} \tag{19}$$

In case of the control of the milling cutter, the middle point of the tool is controlled. Based on Fig. 9, the x additional distance has to be considered (Fig. 10):

$$x = \sqrt{h \cdot (D-h)} \tag{20}$$

Considering the overruns (l_1, l_2), the computed machine time is:

$$T_g = \frac{L}{v_f} \cdot z = \frac{x + l_1 + l + l_2 + x}{v_f} \cdot z \tag{21}$$

Another milling possibility is the groove milling by hob [1, 2, 4] (<https://www.banki-sos.hu/bordastengely->

[bordastengelyek-bordas-tengely/bordastengelyek-bordastengely-bordas-tengely-197](https://www.banki-sos.hu/bordastengely-)). It is economical in case of serial production because of the complexity of the cutting tool and the short computed machine time (Fig. 11).

Based on Fig. 11, the hob is doing rotation and parallel motion with the axis of rotation of the spline shaft, while the spline shaft is doing rotation motion. The cutting teeth are situated around the perimeter of the hob on helical path. The manufacturing process is shorter than the previous case that is why it is applicable in case of serial production. There are many teeth which have to be grinded along the face surface and the side surfaces on the tool as well. That is why the manufacturing process is quite complex and takes much time [9]. Consequently, the price of this hob is high.

The transformation matrix between the hob and the spline shaft is:

$$M_{2R,1R} = \begin{bmatrix} \sin\varphi_1 \cdot \cos\varphi_2 & \sin\varphi_1 \cdot \sin\varphi_2 & \cos\varphi_1 & -t \cdot \cos\varphi_1 + v_f \cdot \sin\varphi_1 \\ \cos\varphi_1 \cdot \cos\varphi_2 & \cos\varphi_1 \cdot \sin\varphi_2 & -\sin\varphi_1 & t \cdot \sin\varphi_1 + v_f \cdot \cos\varphi_1 \\ -\sin\varphi_2 & \cos\varphi_2 & 0 & -s \\ 0 & 0 & 0 & 1 \end{bmatrix} \tag{22}$$

The contact points between the hob and the spline shaft could be calculated by Eqs. (3), (4), (5), (6), (7) and (22) [8].

The spline fitting could be also manufacturable by end mill (Fig. 12) [10–12]. The axis of rotation of the end mill cutter is perpendicular for the centre line of the spline shaft.

The arc of contact between the milling cutter and the work-piece during the chip separation process is:

$$i = \frac{D \cdot \pi \cdot (\varphi_1 + \varphi_2)}{360^\circ} = \frac{D \cdot \pi}{2} \tag{23}$$

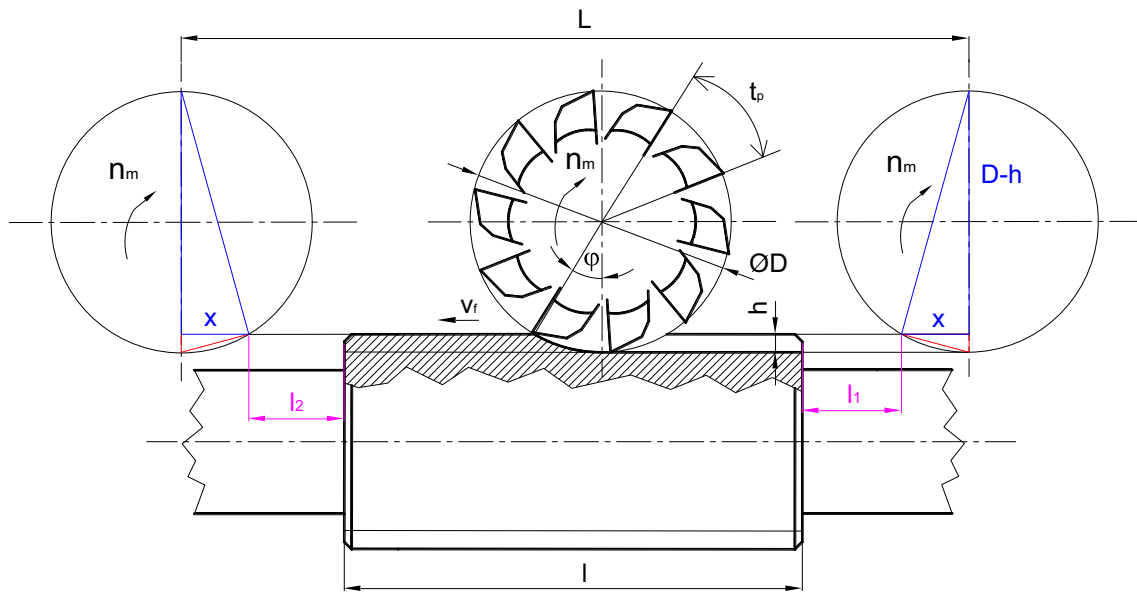

Fig. 10 Determination of the computed machine time

The switching number is:

$$\Psi = \frac{i}{t} = \frac{z}{2} \tag{24}$$

The (10), (11), (14), (18) and (19) are valid for this technology as well. The total cutting force is:

$$F_c = z \cdot k_c \cdot h \cdot \frac{f_z \cdot w_1}{D \cdot \pi} \tag{25}$$

Considering the overruns (l_1, l_2), the computed machine time is (Fig. 12):

$$T_g = \frac{L}{v_f} \cdot z = \frac{l_1 + l + l_2}{v_f} \cdot z \tag{26}$$

Fig. 11 The manufacturing process of spline hobbing

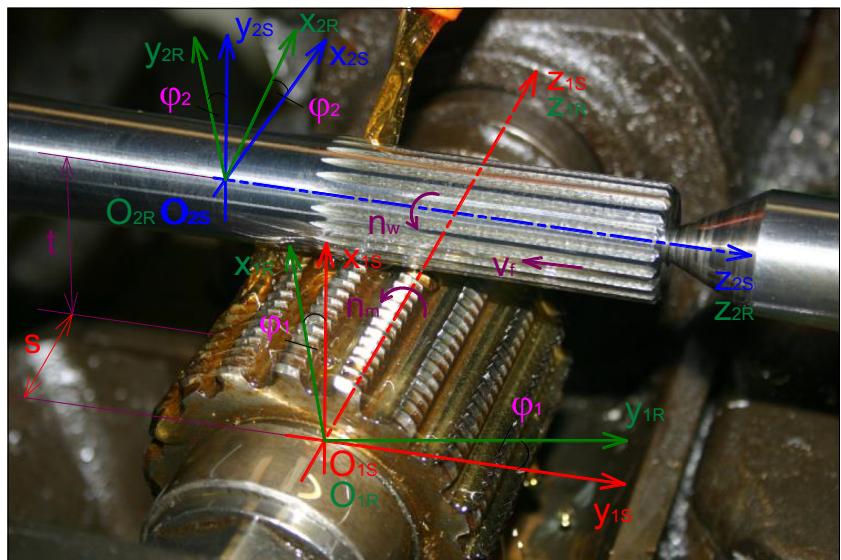

3.2 Grinding technologies for the spline shaft

According to the type of the centralization, there are many grinding possibilities. If the centralization is minor diameter fit or side-bearing fit, the following solutions are recommended (Fig. 13).

The grinding wheel is doing rotation and linear motion at the same time. When one tooth is ready, the division could be solved by dividing head according to the division ratio. After that the grinding of the second spline could be followed. This process has to be repeated in the function of the splines around the perimeter. The side surfaces and the w_2 groove width are grinded.

Fig. 12 The technological process of the spline milling by end mill

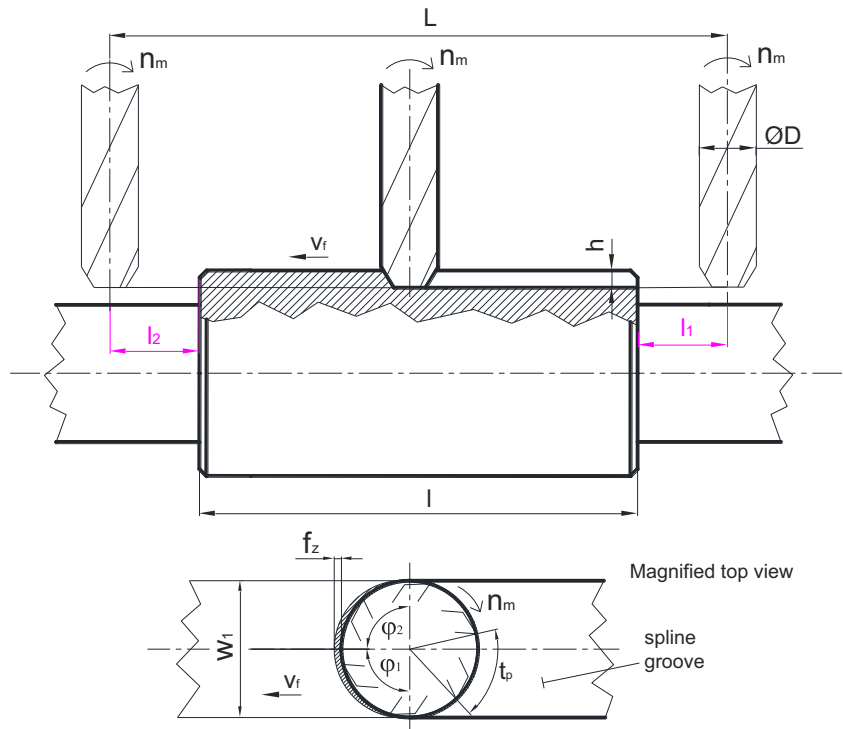

If the centralization is major diameter fit, the traverse grinding technology is recommended (Fig. 14). The axes of rotation of the grinding wheel and the spline shaft are parallel. The grinding wheel is doing rotation motion, while the shaft is doing linear motion. The division process is the same than in the previous case. The tip circle diameter of the shaft is grinded.

Two grinding wheels are applied on Fig. 15 a and b. This solution is favourable for side-bearing fit in case of serial production. Only the w_2 groove width on the root circle diameter is grinded on Fig. 15c. It could be used for minor diameter fit.

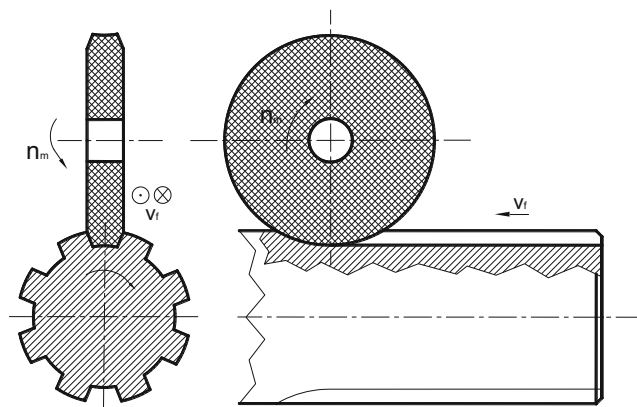

Fig. 13 Grinding of the spline grooves of a spline shaft by formed disc-type grinding wheel

3.3 Manufacturing of the hole grooves by slotting technology

The manufacturing of the hole grooves could be happened by slotting technology. The whole depth of cut is the groove depth. The cutting tool is doing alternation motion which is parallel with the axis of rotation of the workpiece. After the removal of the a_1 depth of cut, the process could be repeated until the removal of the whole depth of cut (a). After that the workpiece has to be divided into the following groove position, and the process could be repeated (Fig. 16).

The total computed machine time depends on the number of the grooves:

$$T_g = \frac{L}{v_f} \cdot z = \frac{l_1 + l + l_2}{v_f} \cdot z \tag{27}$$

3.4 Grinding technologies for the spline hole

After the slotting process the grooves has to be grinded based on the centralization versions (Figure 17).

Figure 17a solution is appropriate for grinding of hole grooves in case of major diameter fit and side-bearing fit. The grinding wheel is doing rotation motion (v_c) around its own axes, while the spline hole is doing linear feed motion (v_f). After the grinding of one groove, the grinding wheel has to be removed. The spline hole has to be divided by one pitch (into the other groove position). After that the grinding

Fig. 14 Traverse grinding technology in case of major diameter fit

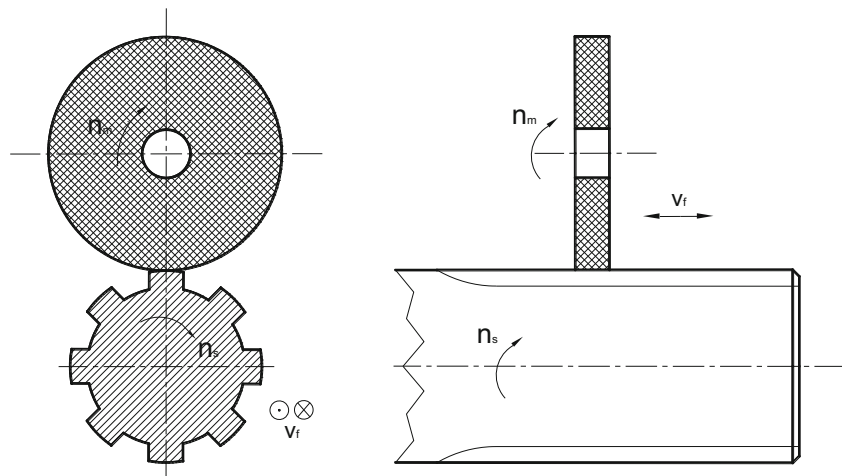

process could be continued. The computed machine time depends on the number of teeth.

Figure 17b solution could be applicable in case of minor diameter fit. In this case, the D_a tip circle diameter of the hole has to be grinded. The grinding wheel is doing rotation motion (v_{c1}) around its own axes, while the spline hole is doing linear feed motion (v_f) and rotation motion around its own axes (v_{c2}) at the same time.

4 Conclusion

The aim of this study is the analysis and development of the manufacturing technologies for spline fittings (spline shaft and spline hole). They could be manufactured by conventional machines and CNC machines [13] as well.

The most widespread milling technology for the spline shaft is the plain milling technology. We created a mathematical model for the technological analysis, researches and

designing. We calculated the contact points between the tool and the workpiece by mathematical way during the milling process. Knowing of the geometric equation of the cutting tool the milled surface could be defined by double-wrapping method. Consequently, the surface quality is modelled and the real CAD models could be created. This mathematical algorithm could be also used in case of CNC designing [13] and three coordination measurements. Certainly, the wearing effect of the cutting tool could be also considerable because the sharpening happened on the head surface of the tool. Since new cutting edges are developed, the shape of the milling surface will be changed.

We defined all of the technological parameters, which are needed for the technological designing and machine setting. The cutting tool is a disc-type milling cutter with which the operation could be done on a conventional vertical knee-type milling machine. The disadvantage of this technology is slow because the milling of one spline has to be repeated in the function of the number of splines.

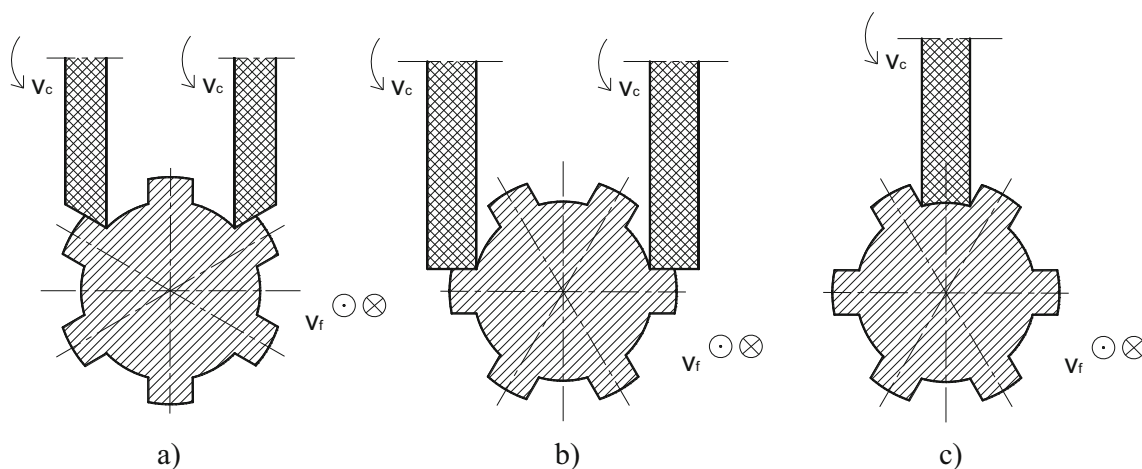
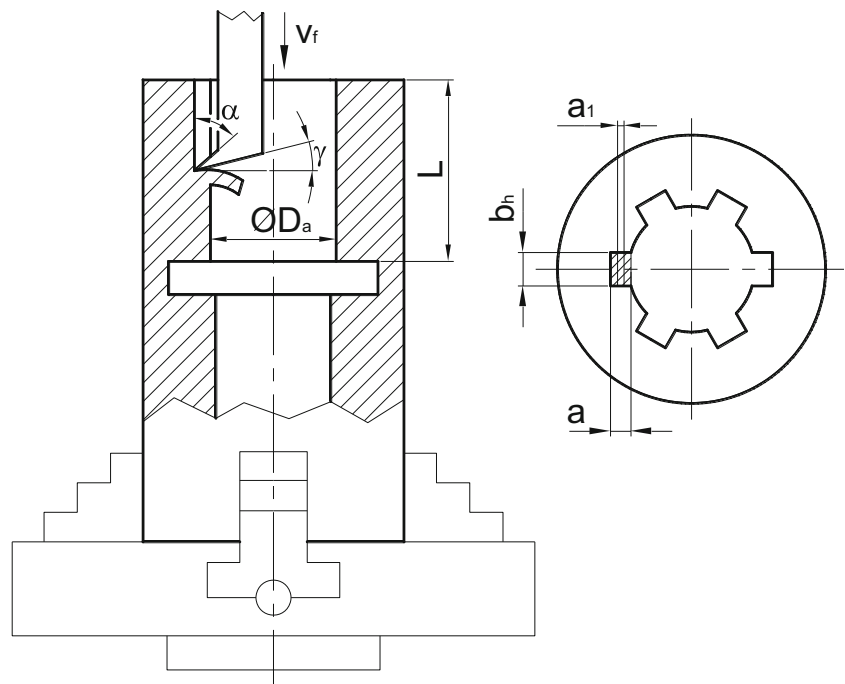

Fig. 15 Other grinding possibilities of spline shaft: (a) grinding by double conical disc-type grinding wheel, (b) grinding by double disc-type grinding wheel and (c) grinding only on the root circle diameter

Fig. 16 Manufacturing of the grooves of the spline hole by slotting technology



It is possible to use hob for the enhancement of the labour productivity. Because of the complex geometry, it is high tool cost that is why it is economical in case of serial production. We also created a mathematical model for this technology. Based on the determined mathematical formulas, the contact points between the connecting surfaces could be calculated. Since the hob has to be resharpener along the head surface, the side surfaces and the back surfaces, new cutting edges will be created in another surface quality. This phenomenon could be followable by this mathematical model.

Due to the insurance of the good surface connection, the connecting surfaces have to be grinded according to the centralization versions. We recommended technologies for it and analysed them.

The slotting technology is the appropriate technology for the creation of the grooves into the spline hole. It could be done on a conventional slotting machine. This technology was also analysed by the technological parameters. Whereas this solution is slow but it gives acceptable accuracy. Certainly, after that the connecting surfaces have to be grinded based on the centralization type.

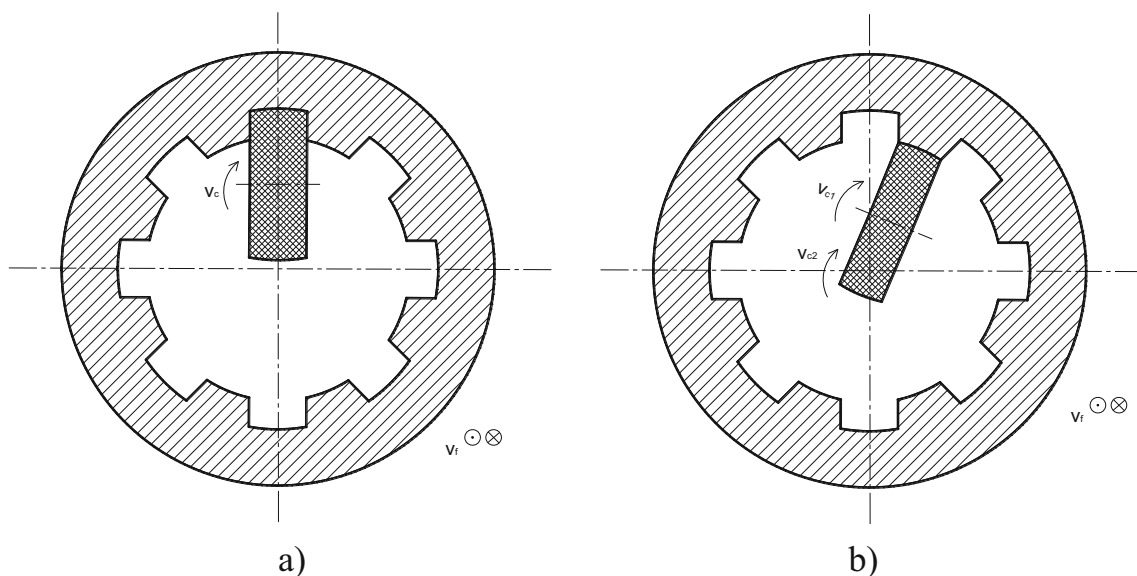

Fig. 17 The grinding possibilities for hole grooves

This publication is theoretical and practical at the same time since it gives directions for the technological designers to design manufacturing technologies for these elements.

Funding Open access funding provided by University of Debrecen.

Nomenclature \vec{n}_{1R} , normal vector of the surface in K1R coordinate system; \vec{r}_{1R} , placement vector of the moving points of the profile curve; \vec{v}_{1R} , relative velocity vector ($\text{mm}/\text{min}^{-1}$); \bar{h} , medium chip thickness (mm); F_{cl} , cutting force for one edge (N); $M_{2R, 1R}$, $M_{2R, 1R}$, transformation matrixes; $\frac{d}{dt}M_{2R, 1R}$, $M_{2R, 1R}$ derivative matrix; k_c , specific cutting force (N/mm^2); A , loaded surface (mm^2); a , common connecting height (mm); a_1 , depth of cut (mm); b_h , spline width of the spline hole (mm); b_s , spline width of the spline shaft (mm); D , outside diameter of the milling cutter (mm); d_a , tip circle diameter of the spline shaft (mm); D_a , tip circle diameter of the spline hole (mm); d_f , root circle diameter of the spline shaft (mm); D_f , root circle diameter of the spline hole (mm); F_c , total cutting force (N); F_{per} , perimeter force on the splines (N); f_s , feed for one edge (mm); h , groove depth (mm); i , arc of contact (mm); K_{1R} (x_{1R} , y_{1R} , z_{1R}), rotational coordinate system related to the cutting tool; K_{1S} (x_{1S} , y_{1S} , z_{1S}), static coordinate system related to the cutting tool; K_{2R} (x_{2R} , y_{2R} , z_{2R}), rotational coordinate system related to the spline shaft; K_{2S} (x_{2S} , y_{2S} , z_{2S}), static coordinate system related to the spline shaft; l , common connecting length (mm); L , total manufacturing length (mm); l_1 , l_2 , tool overrunings (mm); M , load moment (Nm); n_m , number of revolution of the cutting tool (1/min); n_s , number of revolution of the spline shaft (1/min); O_{1R} , O_{1S} , O_{2R} , O_{2S} , origins of the appropriate coordinate systems; $p_{allowed}$, permissible pressure on the splines (MPa); P_c , cutting power (kW); P_m , motor power (kW); r_b , resultant distance of the surface pressure from the centre line of the shaft (mm); t , s , centre distance between the axes of rotation of the workpiece and the cutting tool (mm); T_g , computed machine time (min); t_p , tooth pitch (mm); v_c , cutting speed (mm/min); v_f , feed speed (mm/min); w_1 , groove width on the tip circle diameter (mm); w_2 , groove width on the root circle diameter (mm); x , additional distance of the milling cutter (mm); x , y , z , coordinates (mm); z , number of splines around the shaft perimeter; z_b , number of teeth on the milling cutter; α , tool clearance ($^\circ$); γ , tool rake ($^\circ$); η , motor efficiency; φ_1 , φ_2 , angular displacement ($^\circ$); Ψ , switching number; Ψ_b , inaccuracy factor ($\Psi_b = 0.75-0.9$); η , ϑ , the two parameters of the cutting edge

Open Access This article is licensed under a Creative Commons Attribution 4.0 International License, which permits use, sharing, adaptation, distribution and reproduction in any medium or format, as long as you give appropriate credit to the original author(s) and the source, provide a link to the Creative Commons licence, and indicate if changes were made. The images or other third party material in this article are included in the article's Creative Commons licence, unless indicated otherwise in a credit line to the material. If material is not included in the article's Creative Commons licence and your intended use is not permitted by

statutory regulation or exceeds the permitted use, you will need to obtain permission directly from the copyright holder. To view a copy of this licence, visit <http://creativecommons.org/licenses/by/4.0/>.

References

- Bálint L (1961) A forgácsoló megmunkálás tervezése. Műszaki Könyvkiadó, Budapest, p 860
- Bali J (1988) Forgácsolás. Tankönyvkiadó, Budapest, p 538
- Terplán Z, Gépelemek I (1972) Nehézipari Műszaki Egyetem, Miskolc, Tankönyvkiadó, Budapest, p 137
- Dudás I.: Gépgyártástechnológia III (2011) A. Megmunkáló eljárások és szerszámaik. B. Fogazott alkatrészek gyártása és szerszámaik; Egyetemi tankönyv., Műszaki Kiadó. p 538, ISBN 978-963-16-6531-4
- Klocke F (2011) Manufacturing processes I, Cutting, RWTH Edition. RWTH Aachen University, p 524 ISBN 978-3-642-11978-1
- Groover MP (2010) Fundamentals of modern manufacturing, materials, processes and systems. 3rd edn. United States of America, p 520, ISBN 978-0-471-74485-6
- Bralla JG (2007) Handbook of manufacturing processes, 1st edn. Industrial Press Inc, New York ISBN 0-831 1-3179-9
- Litvin FL, Fuentes A (2004) Gear geometry and applied theory. Cambridge University Press, Cambridge, p 800
- Dudás I, Bodzás S (2013) Production geometry analysis, modeling and rapid prototyping production of manufacturing tool of spiroid face gear. Int J Adv Manuf Technol 66:271–281. <https://doi.org/10.1007/2Fs00170-012-4323-9>
- Gök A, Demirci H, Gök K (2014) Determination of experimental, analytical and numerical of tool deflection at ball end milling of inclined surfaces. Proceedings of the Institution of Mechanical Engineers Part E-Journal of Process Mechanical Engineering 230: 111–119. <https://doi.org/10.1177/0954408914540633>
- Liu X-W, Cheng K, Longstaff A (2005) P., Widiyanto, M. H., Ford, D.: Improved dynamic cutting force models in ball-end milling part I: theoretical modelling and experimental calibration. Int J Adv Manuf Technol 26:457–465. <https://doi.org/10.1007/s00170-003-2014-2>
- Gök A, Gologlu C, Demirci HI (2013) Cutting parameter and tool path style effects on cutting force and tool deflection in machining of convex and concave inclined surfaces. Int J Adv Manuf Technol 69(5-8):1063–1078
- Kief HB, Roschiwal HA (2011) CNC Handbook. Carl Hanser Verlag GmbH & Co. KG, München ISBN 978-07179948-5

Publisher's note Springer Nature remains neutral with regard to jurisdictional claims in published maps and institutional affiliations.